

# Lattice Gauge Theory

Barak Bringoltz, Masanori Hanada, Stephen Sharpe, Larry Yaffe

## ★ Students

- Andrew Lytle (now postdoc in Southampton)
- Mateusz Koren (exchange student from Krakow)

## ★ Other UW faculty working in this area:

- Jeff Mandula
- David Kaplan (INT)
- Martin Savage (NT group)
- Huey-Wen Lin (NT group)

# Lattice Projects @ UW during last year

- **“Closed flux tubes and their string description in 3+1d gauge theories”**
  - ▶ [Athenodorou, Bringoltz & Teper, arXiv:1007.4720](#)
- **“Large-N spacetime reduction and the sign and silver-blaze problems of dense QCD”**
  - ▶ [Bringoltz, JHEP 1006:076,2010 \(arXiv:1004.0030\)](#)
- **One-loop matching of improved staggered operators**
  - ▶ [Kim, Lee & Sharpe, PRD81 \(2010\) 114503 \(arXiv:1004.4039\)](#)
  - ▶ [Kim, Lee & Sharpe, Lat10 proceedings--arXiv:1010.5483](#)
- **$B_K$  using improved staggered fermions**
  - ▶ [Sharpe et al., PRD to appear \(arXiv: 1008.5179\)](#)
  - ▶ [Sharpe et al, Lattice 2010 proceedings--arXiv:1010.4778, 4779, 4780, 4781](#)
- **Non-perturbative renormalization using staggered fermions**
  - ▶ [Lytle, thesis; Lytle & Sharpe, in preparation](#)
- **Volume independence of large-N QCD with adjoint fermions**
  - ▶ [Bringoltz, Koren & Sharpe, in preparation](#)

# $B_K$ with improved staggered fermions

With Chulwoo Jung (BNL), Weonjong Lee (Seoul  
National), & students

# Aims of project

- Calculate  $B_K$  and related matrix elements with few percent precision

$$\frac{8}{3}m_k^2 f_K^2 B_K = \langle \bar{K} | \bar{s} \gamma_\mu (1 - \gamma_5) d \bar{s} \gamma_\mu (1 - \gamma_5) d | K \rangle$$

- $B_K$  determines CP violation in  $K_0$  mixing in Standard Model (SM)
- Beyond the Standard Model (BSM) theories involve related matrix elements
  - ➔ Constraints on BSM theories complementary to those from the LHC
- LQCD needs results from several fermion types
  - ➔ Our calculations complementary to those with Domain-wall fermions
  - ➔ We use 4 lattice spacings compared to 2-3 for DWF

# Status of lattice calculations of $B_K$

Laiho, Lunghi, Van de Water (2009)

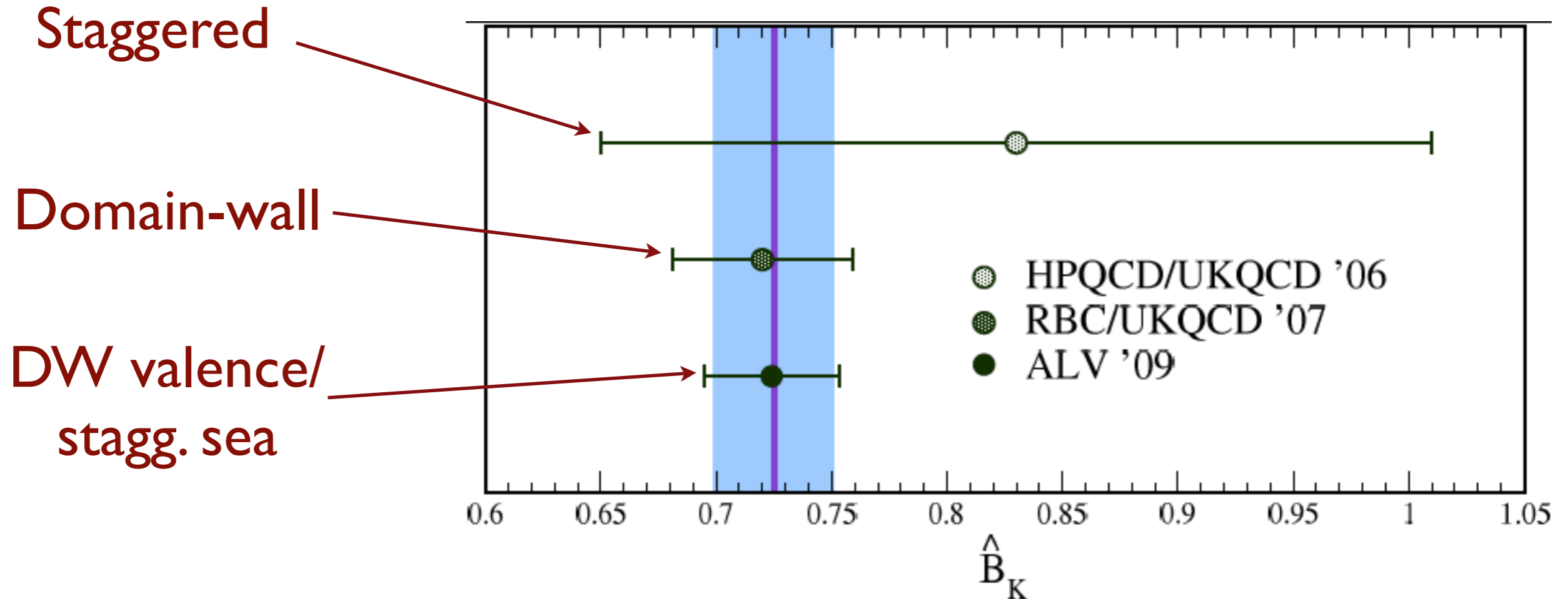

Our aim: competitive results with staggered valence/sea

# Status of lattice calculations of $B_K$

Laiho, Lunghi, Van de Water (2009)

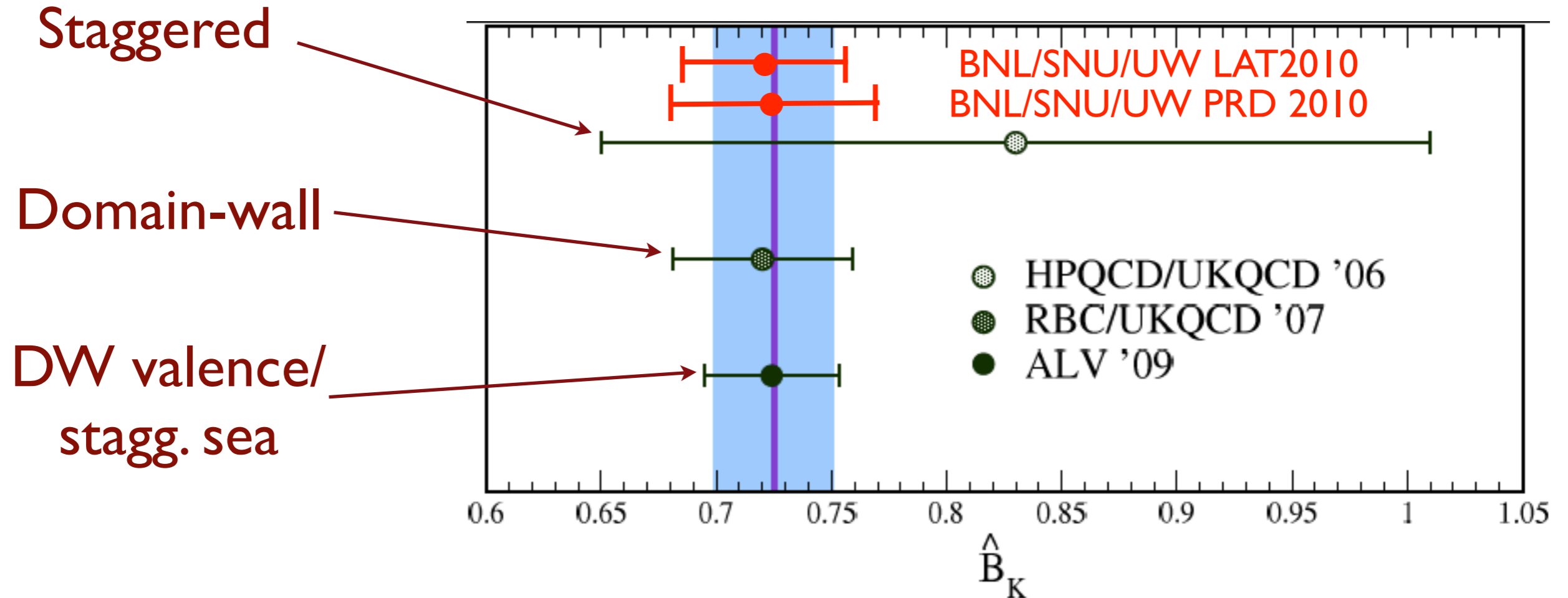

Aim achieved: we published a competitive result,  
and further improved on it.  
Excellent agreement among lattice results!

# Testing the SM: tension?

Laiho, Lunghi, Van de Water (2009)

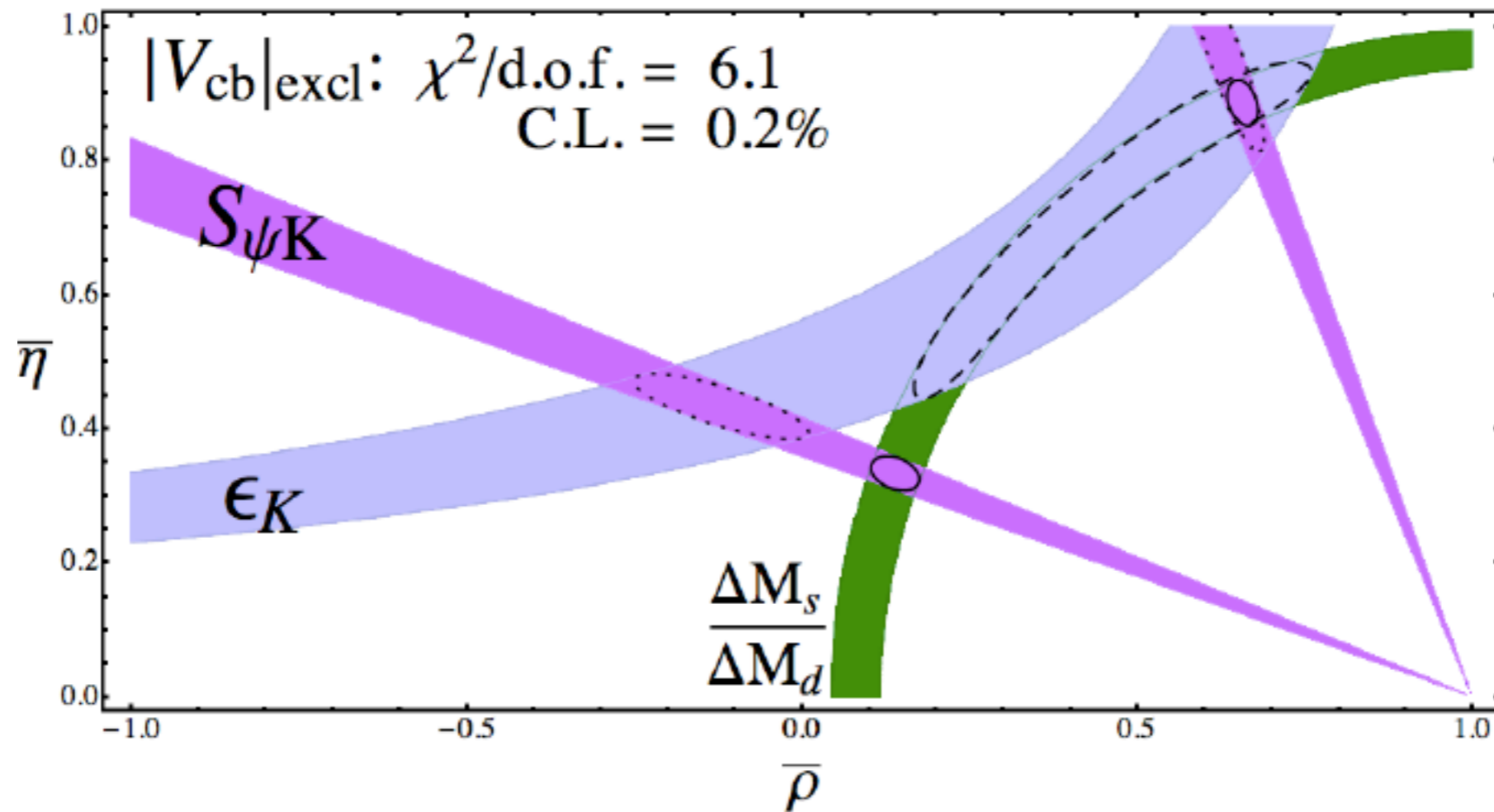

Present lattice average

$$\hat{B}_K = 0.725 \pm 0.026$$

CKM prediction:

$$(\hat{B}_K)_{\text{fit}} = \begin{cases} 1.09 \pm 0.12 & |V_{cb}|_{\text{excl}} \\ 0.903 \pm 0.086 & |V_{cb}|_{\text{incl}} \\ 0.98 \pm 0.10 & |V_{cb}|_{\text{excl+incl}} \end{cases}$$

# Calculating $B_K$

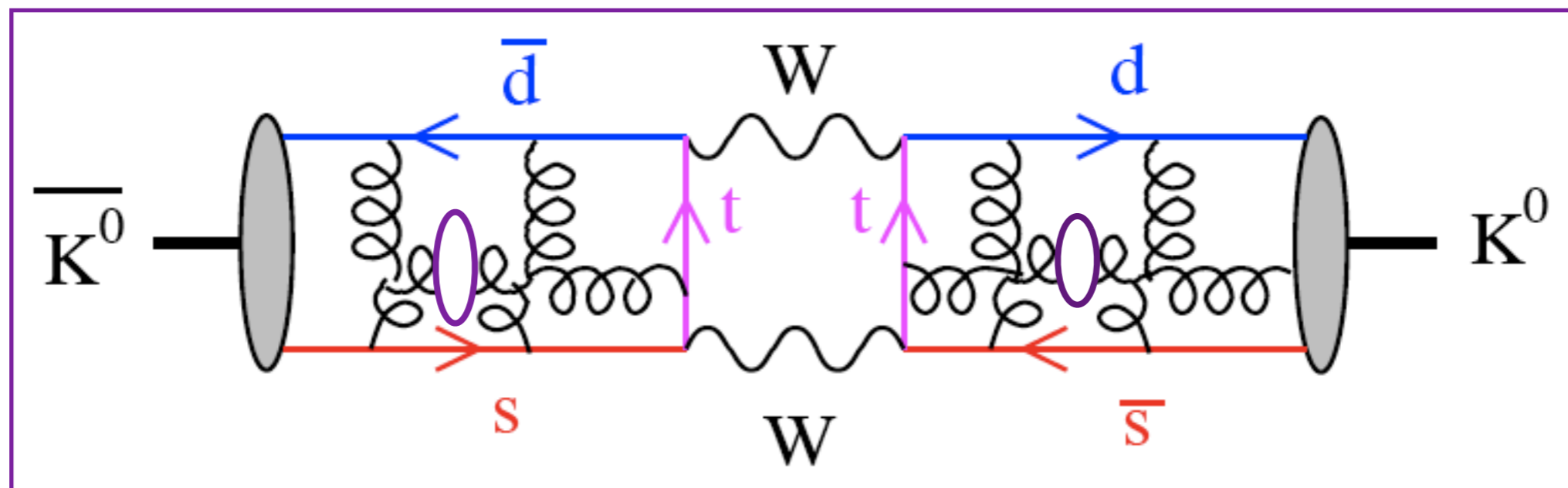



# Calculating $B_K$

Known local four-fermion operator

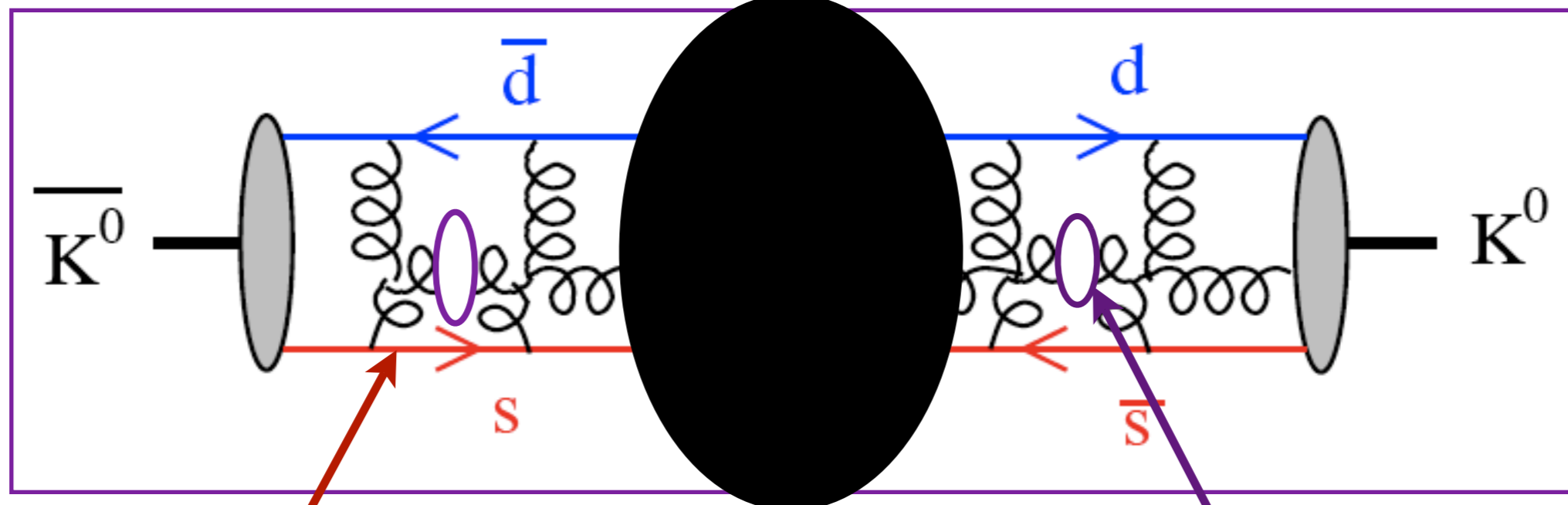

Valence quarks with improved coupling to gluons and partial chiral symmetry

Gauge configuration including sea-quark loops (MILC)

# Systematic errors

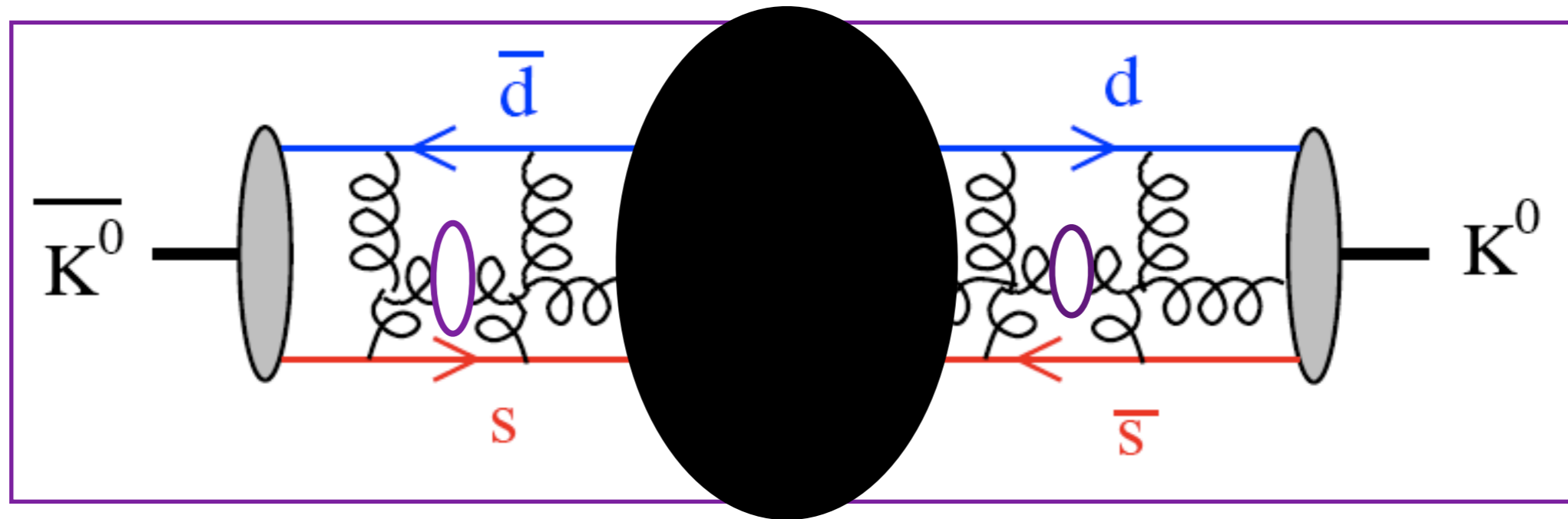

# Systematic errors

Matching lattice and continuum operators

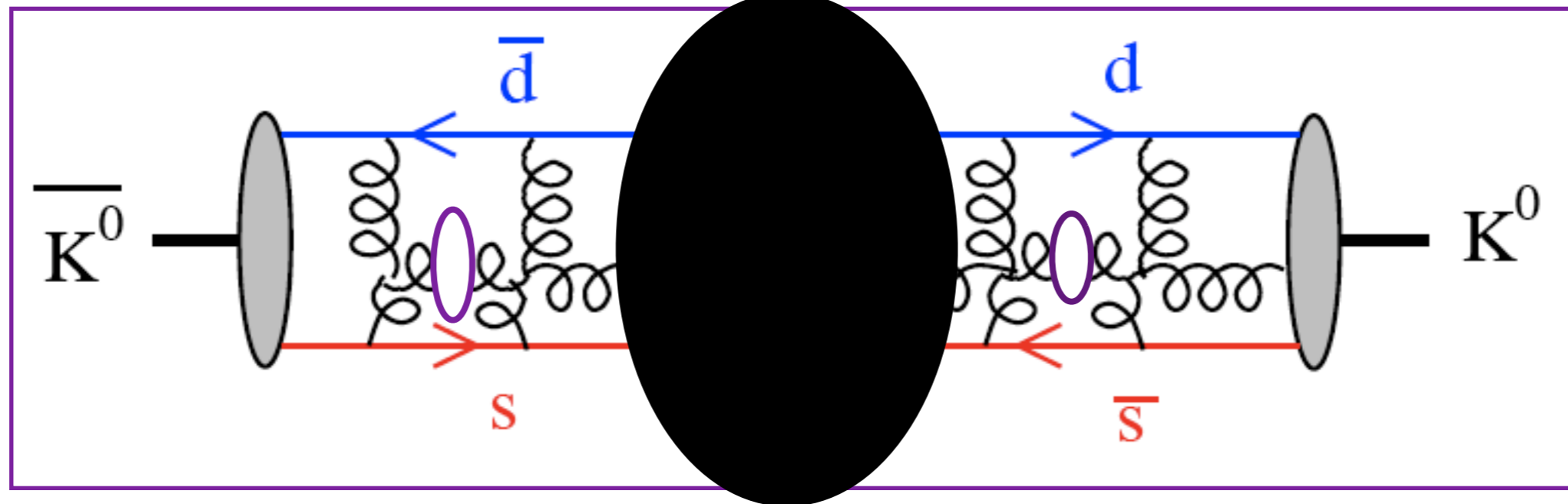

# Systematic errors

Matching lattice and continuum operators

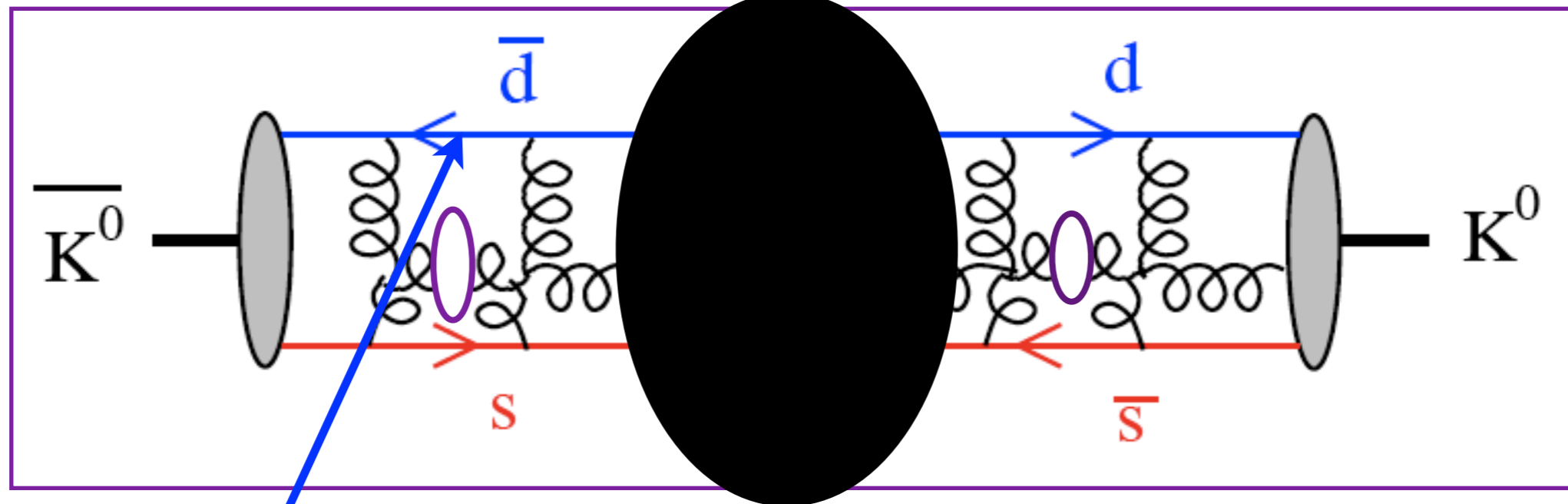

Need for chiral extrapolation of  $m_d$  to physical value

# Systematic errors

Matching lattice and continuum operators

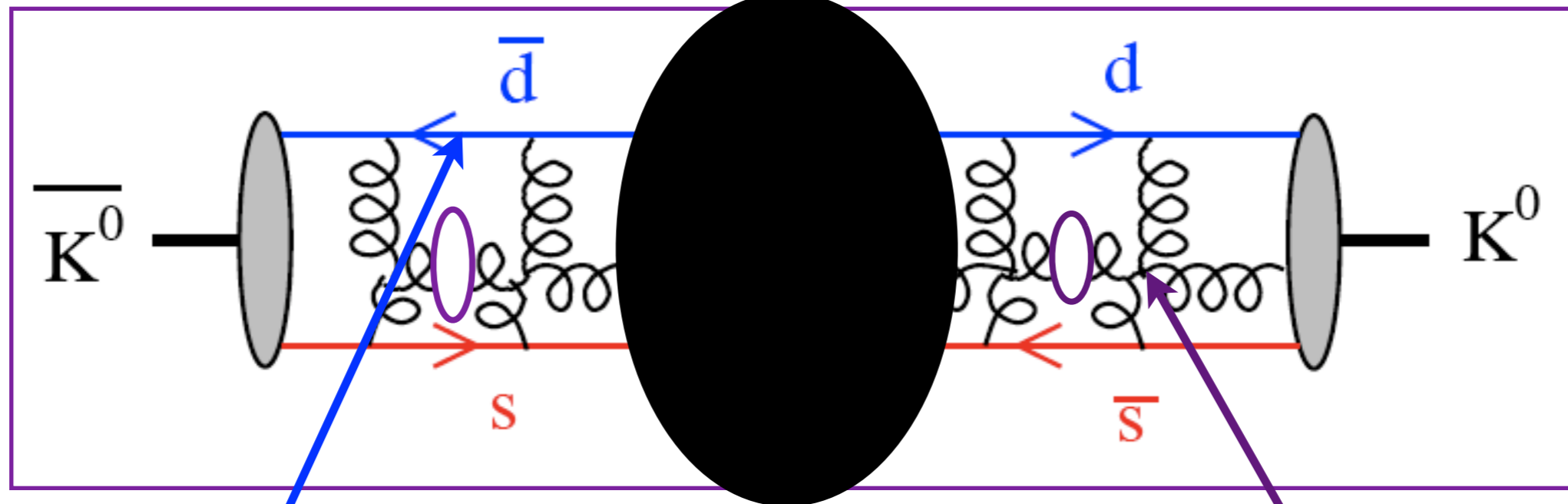

Need for chiral extrapolation of  $m_d$  to physical value

Discretization errors (taste breaking) and finite volume errors

# Methodology

- Use existing MILC ensembles
  - ➔ Improved, rooted staggered sea quarks
  - ➔  $a=0.12, 0.09, 0.06$  &  $0.045$  fm
- “HYP” smeared valence staggered quarks
  - ➔ Discretization errors reduced by 3 compared to sea quarks
- USQCD allocation on QCDOC
  - ➔ 1.2 Mnode-hrs in 06/07, 3.25 in 07/08, 12 in 08/09, 25 in 09/10, 20 in second half of 2010 (until machine shutdown)
  - ➔ 75K GPU-hours in second half of 2010

# Status of $B_K$ calculation 11/10

- One-loop matched  $B_K$  data at **four** lattice spacings:

➔  $a=0.12$  fm,  $0.09$  fm,  $0.06$  fm, and  $0.045$  fm

- Results from 3 lattice spacings **published**

➔ Complete error budget, 6.2% total error

➔ Result consistent with ALV & RBC

- Chiral perturbation theory analysis **published**

- One-loop perturbative matching **published**

- **Preliminary results with four lattice spacings**

➔ Total error reduced to 4.8%

**New this  
year**

# Continuum extrapolation

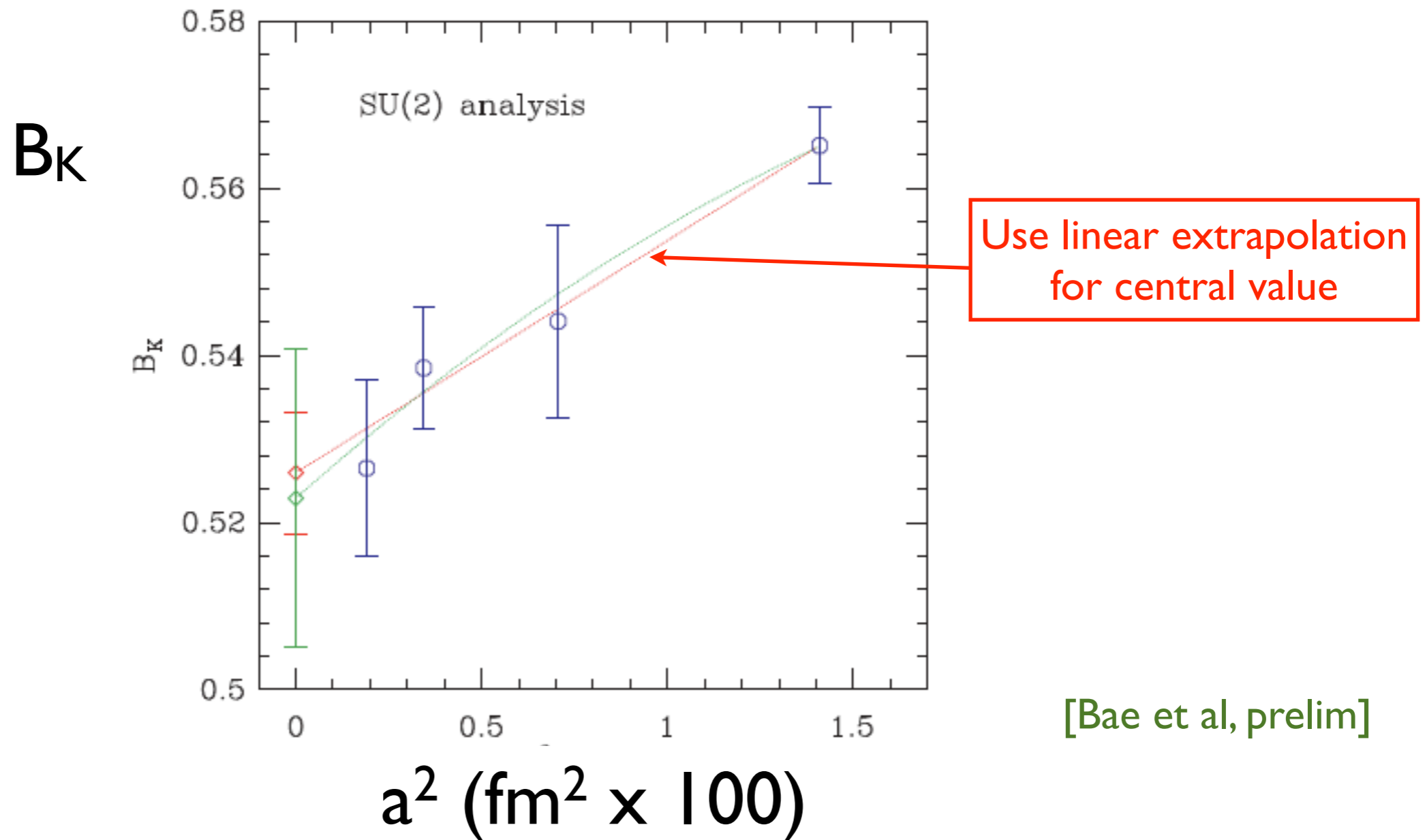

# Continuum extrapolation

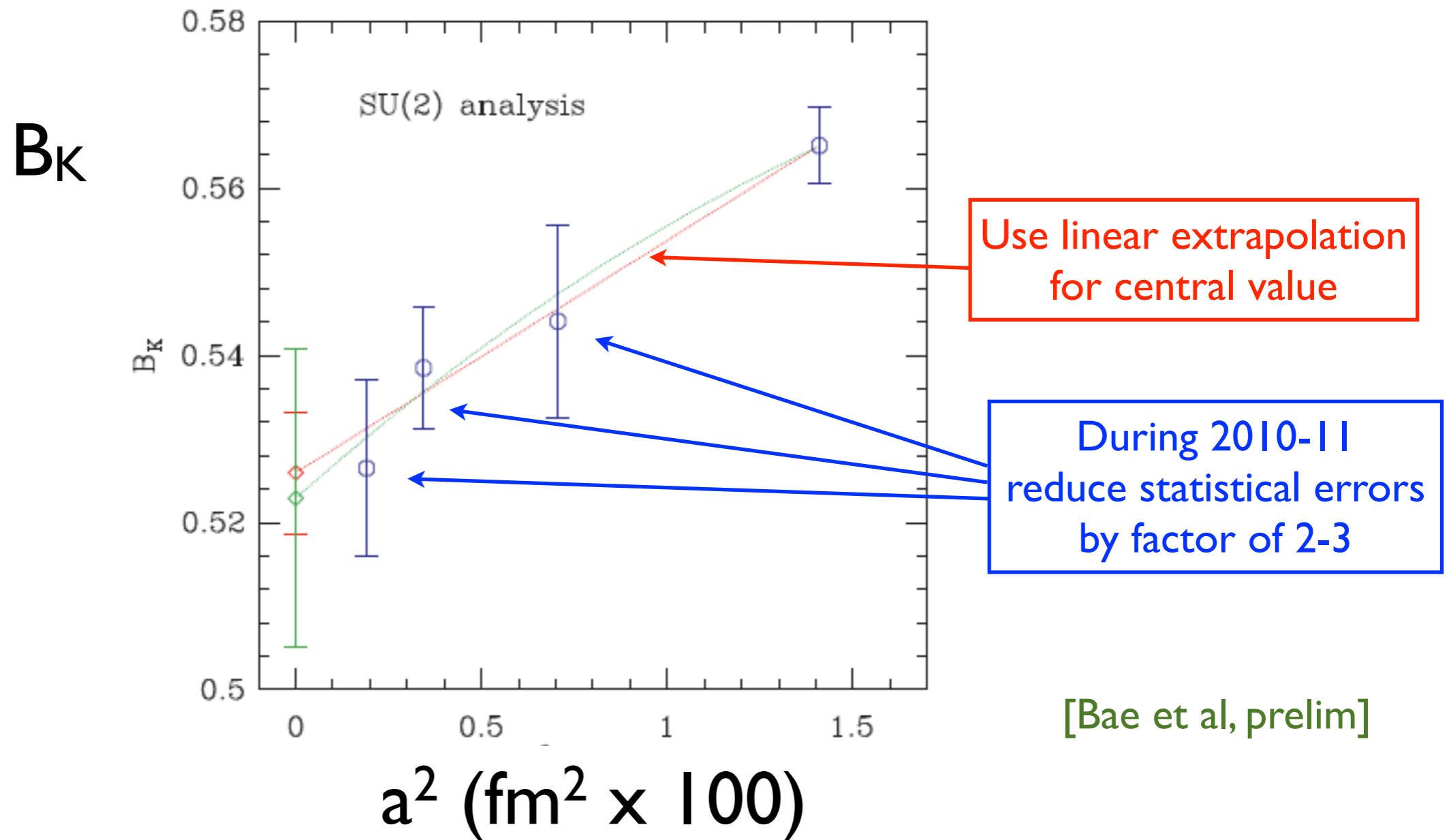

# Error budgets

## Published result (3 lattice spacings)

- Total error 6.2%, dominated by matching error

TABLE XXX: Error budget of  $B_K$  in the SU(2) fitting.

cause	error (%)	memo
statistics	1.7	4X3Y NNLO fit
matching factor	5.5	$\Delta B_K^{(2)}$ (S1)
discretization	1.8	diff. of (S1) and ( $a=0$ )
fitting (1)	0.92	X-fit (C3)
fitting (2)	0.08	Y-fit (C3)
$am_l$ extrap	0.48	diff. of (C3) and linear extrap
$am_s$ extrap	0.5	constant vs. linear extrap
finite volume	0.85	diff. of $20^3$ (C3) and $28^3$ (C3-2)
$r_1$	0.14	$r_1$ error propagation
$f_\pi$	0.38	132 MeV vs. 124.4 MeV

## Updated (Lattice 2010) (4 lattice spacings)

- Total error reduced to 4.8%

cause	error (%)	memo
statistics	1.4	4X3Y-NNLO fit
matching factor	4.4	$\Delta B_K^{(2)}$ (U1)
discretization	0.10	diff. of (U1) and $a = 0$
fitting (1)	0.92	X-fit (C3)
fitting (2)	0.08	Y-fit (C3)
$am_l$ extrap	0.48	diff. of (C3) and linear extrap
$am_s$ extrap	0.5	constant vs linear extrap
finite volume	0.85	diff. of $20^3$ (C3) and $28^3$ (C3-2)
$r_1$	0.14	$r_1$ error propagation

# Plans for upcoming year

- Complete analysis with full  $a=0.045$  fm ensemble and second  $a=0.06$  fm ensemble
- Reduce statistical errors (using GPUs at JLab/SNU)
- Implement 2-loop & non-perturbative normalization
  - ➔ Reduce/remove largest systematic
- Present results for related matrix elements
  - ➔ Relevant for BSM theories

# Non-perturbative renormalization for improved staggered fermions

Lytle & Sharpe

# Aims of project

- Matching is required to connect lattice and continuum regularized matrix elements (e.g.  $m_s$ ,  $B_K$ )
  - ➔ Perturbative error too large for many precision tests
- Non-perturbative renormalization (NPR) replaces truncation error with statistical error
- Apply to MILC and HYP improved staggered fermions
  - ➔ First for quark bilinears (e.g.  $m_s$ ), then four-fermion operators ( $B_K$ )

# Bilinear matching

- Comparison of ratios of Z-factors for bilinears with same spin but differing taste to one-loop pert. thy.

[Lytle, thesis]

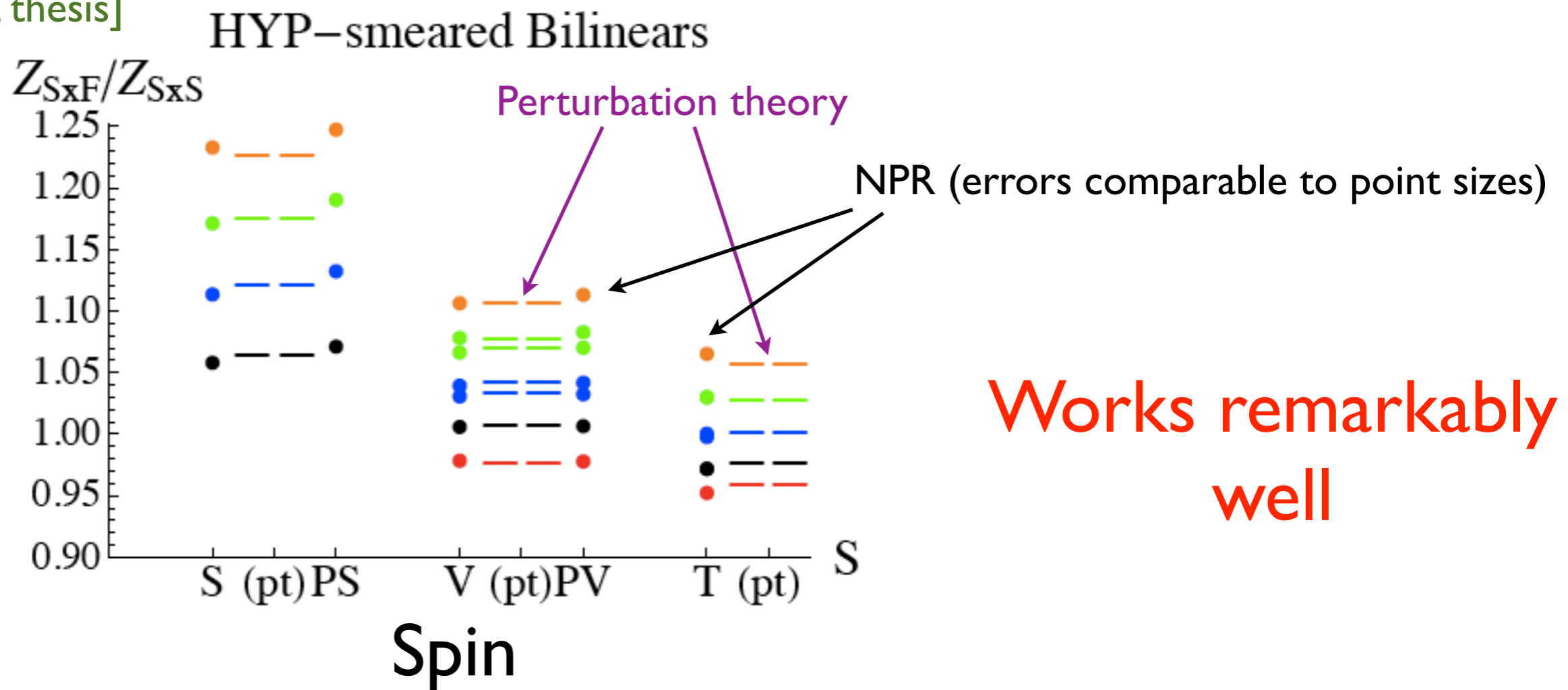
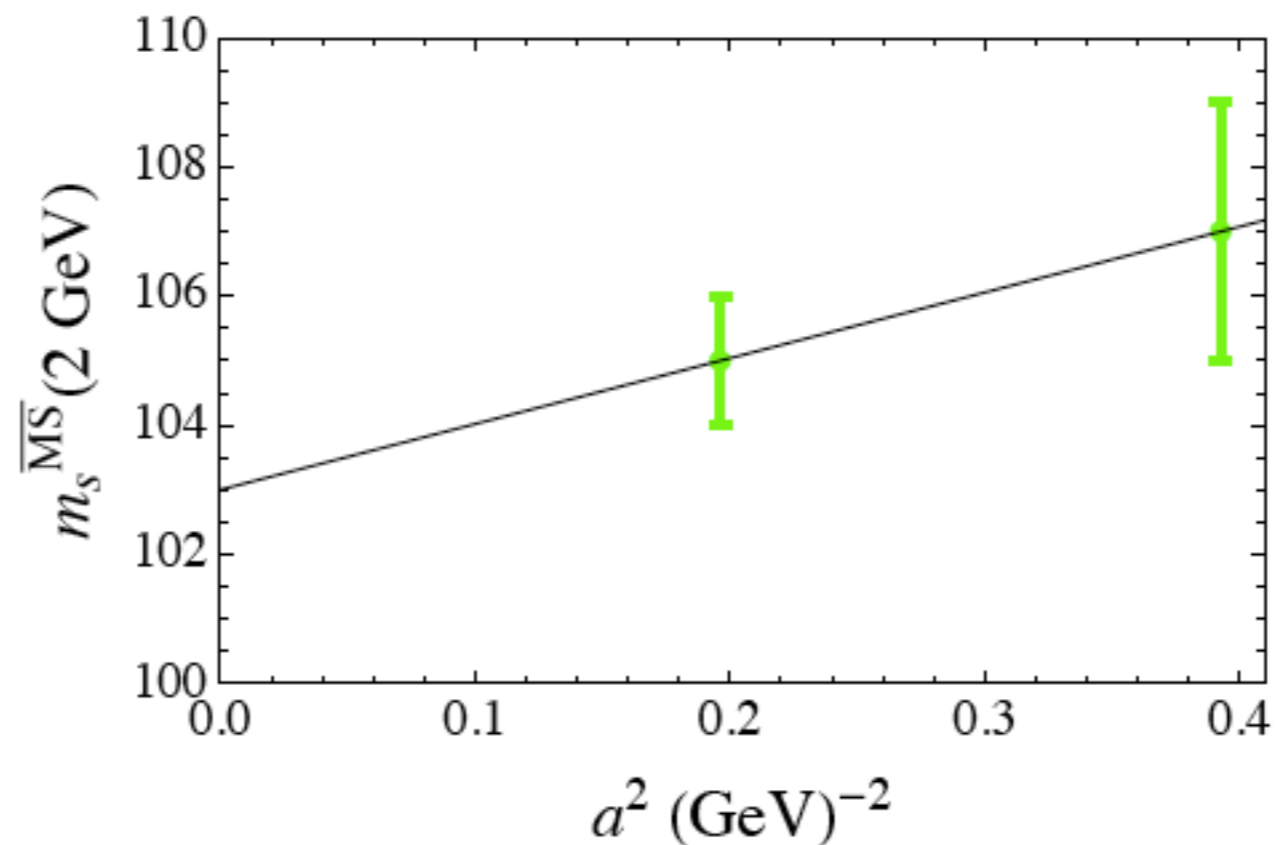

Figure 3.10: A comparison of HYP-smeared bilinear ratios with the predictions of one-loop staggered perturbation theory. This partially quenched data was computed using 4 coarse configurations with  $(am_{\text{sea}}, am_{\text{val}}) = (.03, .03)$ .  $(ap)^2 \approx 1.66$

# $m_s$ with asqtad fermions

- MILC result from  $a=0.12$  &  $0.09$  fm lattices using 2-loop matching is  $m_s(\overline{MS}, 2 \text{ GeV}) = 87(6) \text{ MeV}$
- NPR result is significantly higher:



➔  $m_s(\overline{MS}, 2 \text{ GeV}) = 103(3)(?) \text{ MeV}$

# Comparison with other results

FLAG (Flavianet Lattice Averaging Group) arXiv:1011.4408

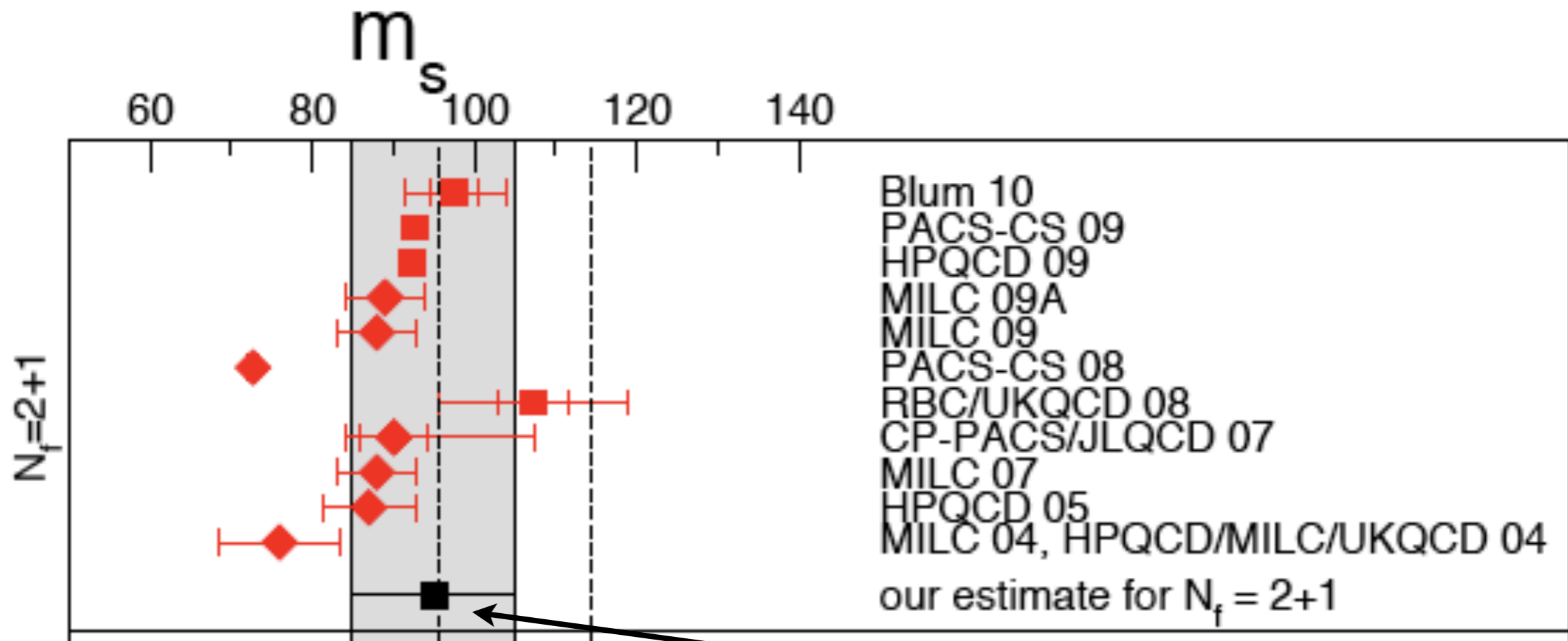

H Lytle, thesis

Their estimate:  
 $m_s = 95(10)$  MeV

# Volume independence of large $N_c$ QCD with adjoint fermions

Bringoltz, Koren & Sharpe

# Volume Independence [Eguchi & Kawai]

- \* Under non-trivial conditions, certain properties of gauge theories at large  $N$  are independent of volume

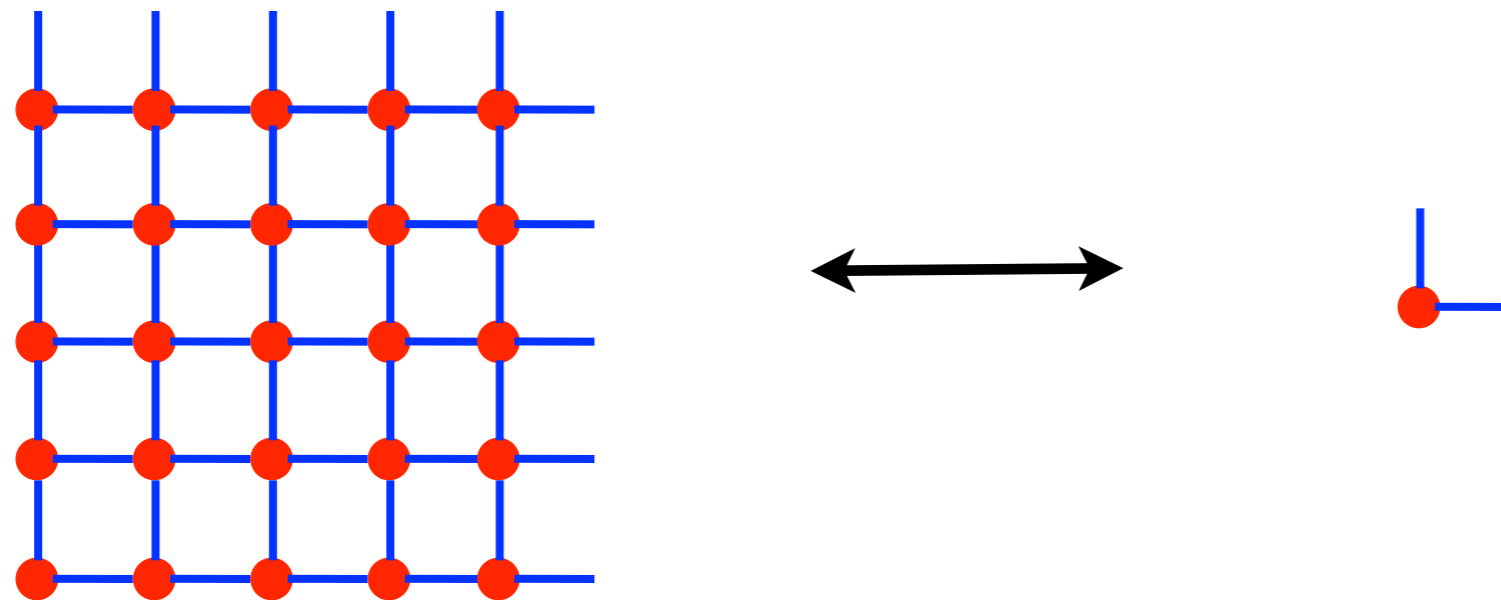

- ➔ Does this reduction in degrees of freedom provide a practical method to access the theoretical simplicity of large  $N$  theories? Are the conditions satisfied?
- ➔ Open questions, under preliminary investigation

# A web of (potential) equivalences

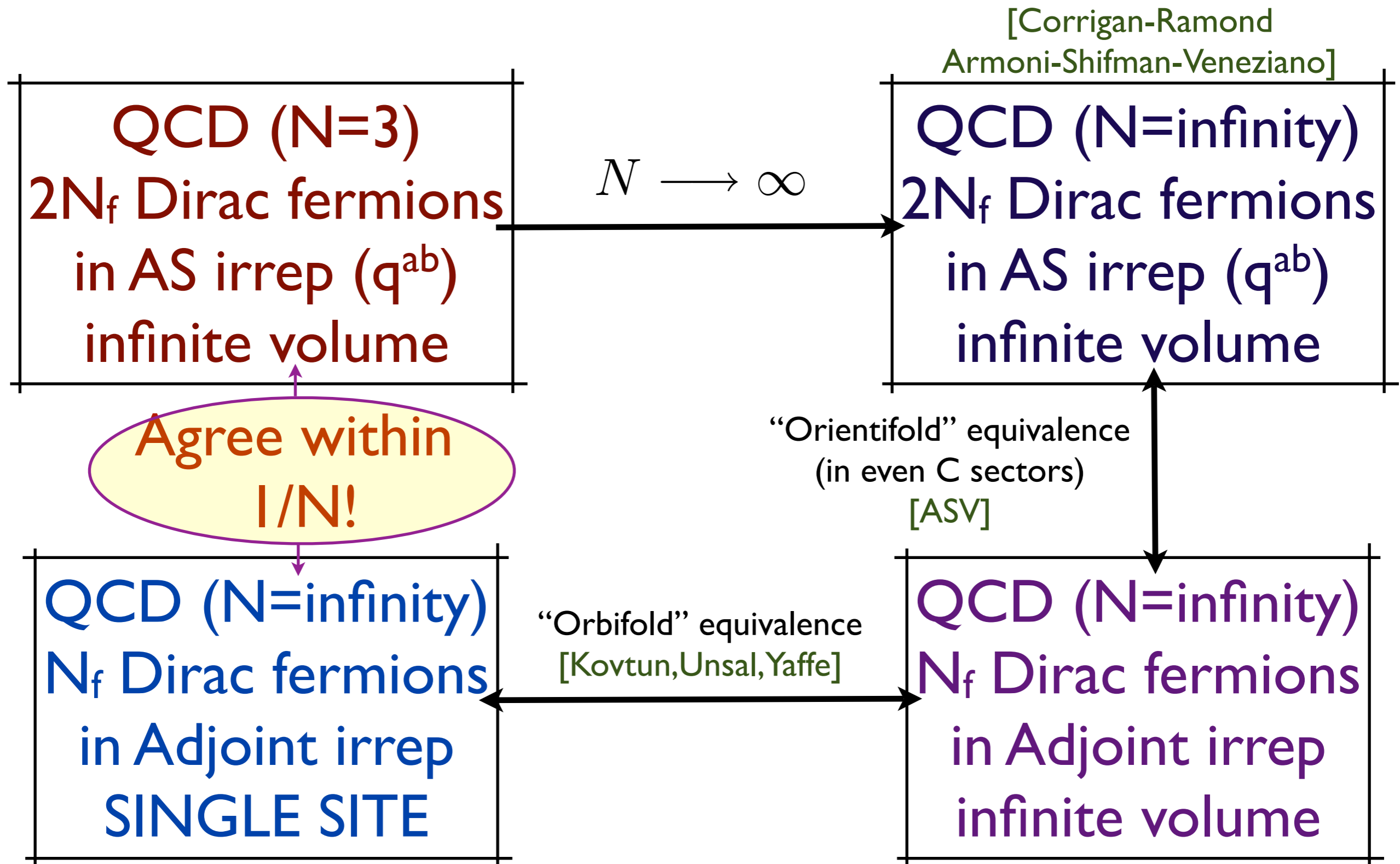

# Overall aim

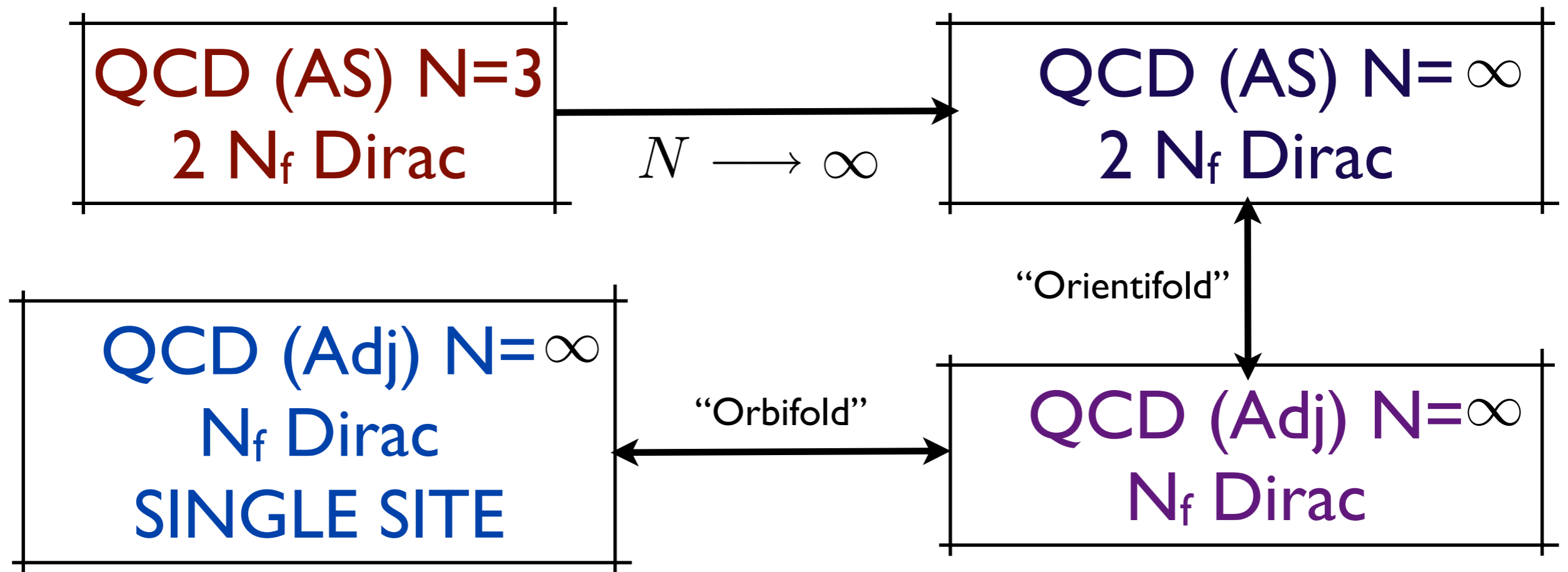

- \* By studying single-site QCD(Adj) for large  $N$  can learn about 3 field theories of great interest ( $N_f=1/2, 1$  &  $2$ )
- \* Can calculate physical quantities (**string tension, pion mass, ...**) even though single-site "matrix model"

# Conditions for equivalences to hold

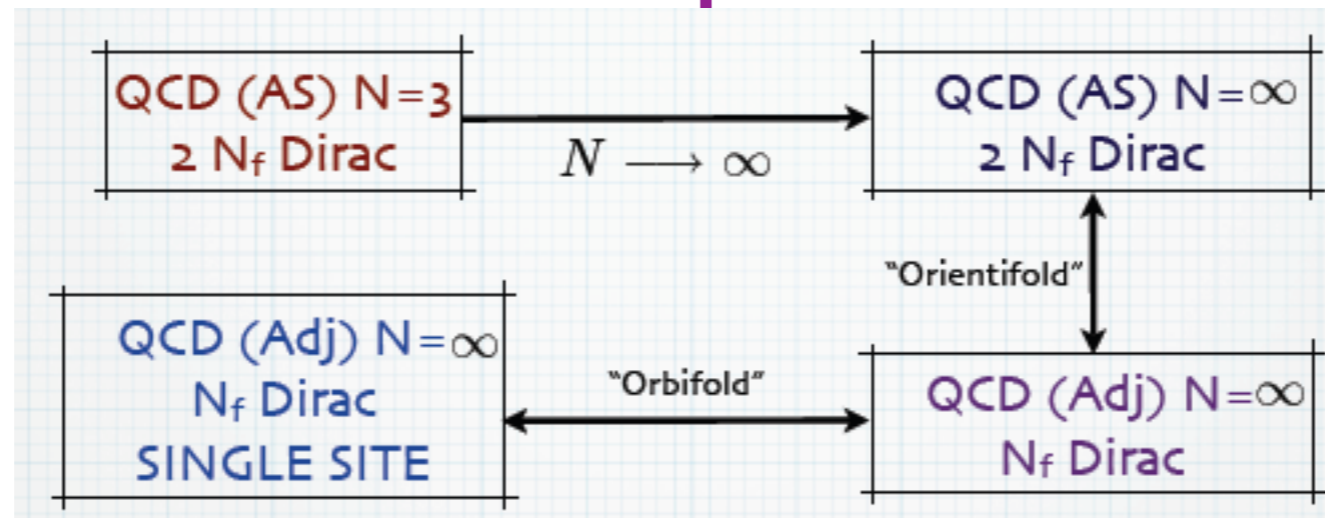

1. Large- $N$  factorization holds
2. Orientifold:  $C$  not broken in QCD(AS,Adj)
3. Orbifold: Translation invariance unbroken in QCD (Adj.) in infinite volume
4. Orbifold:  $(Z_N)^4$  center symmetry unbroken in QCD(Adj.) on a single site

# Conditions for equivalences to hold

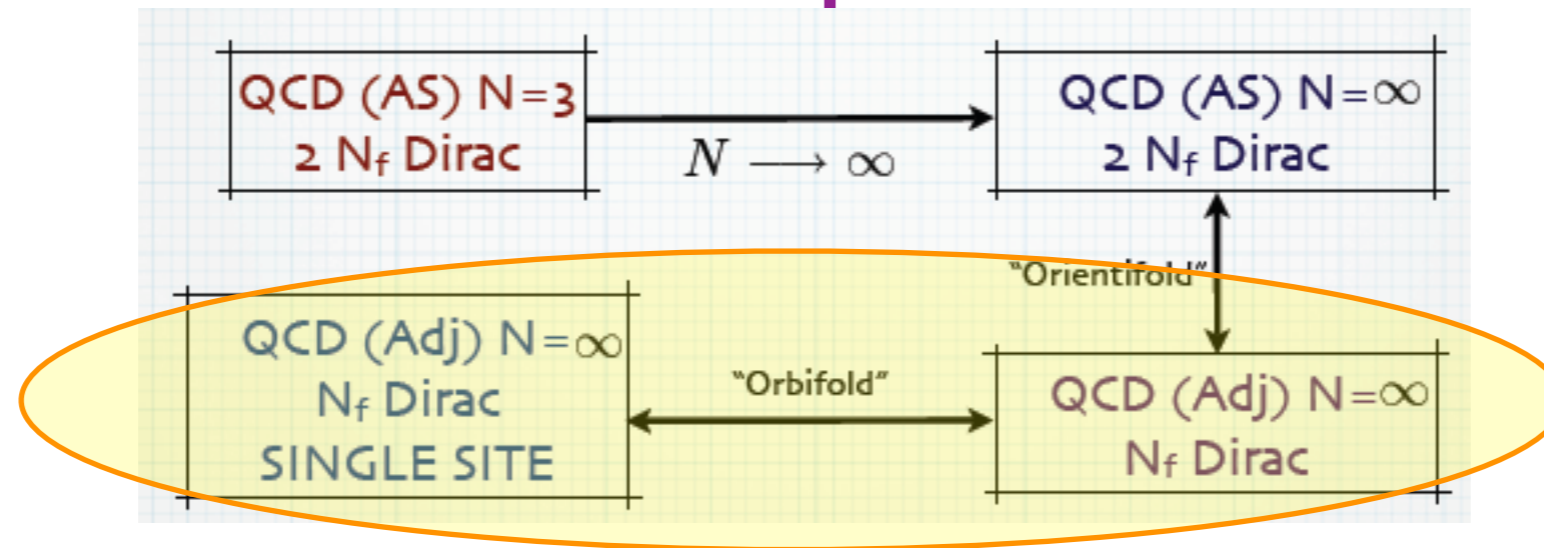

1. Large- $N$  factorization holds
2. Orientifold:  $C$  not broken in QCD(AS,Adj)
3. Orbifold: Translation invariance unbroken in QCD (Adj.) in infinite volume
4. Orbifold:  $(Z_N)^4$  center symmetry unbroken in QCD(Adj.) on a single site

We assume the first three hold and study the last

# Action of AEK model

## Wilson gauge and fermion action

$$S_{\text{gauge}} = 2Nb \sum_{\mu < \nu} \text{ReTr} U_{\mu} U_{\nu} U_{\mu}^{\dagger} U_{\nu}^{\dagger}, \quad b = 1/(g^2 N)$$

$$S_F = \sum_{j=1, N_f} \bar{\psi}_j D_W \psi_j$$

$$D_W = \mathbf{1} - \kappa \sum_{\mu=1}^4 [(1 - \gamma_{\mu}) U_{\mu}^{\text{adj}} + (1 + \gamma_{\mu}) U_{\mu}^{\dagger \text{adj}}]$$

## Symmetries:

**gauge:**  $U_{\mu} \longrightarrow \Omega U_{\mu} \Omega^{\dagger} \quad (\text{all } \mu) \quad \Omega \in SU(N)$

**center  $(Z_N)^4$ :**  $U_{\mu} \longrightarrow U_{\mu} e^{2\pi i n_{\mu}/N} \quad n_{\mu} \in Z_N$

# Scaling of CPU with N

- \* Last year we used Metropolis algorithm

$$P(U) = e^{S_{\text{EK}}(U)} (\det D_W)^{N_f}$$

- Determinant real & positive; evaluate explicitly
- Scaling is  $\sim(N^2)^3 \times N^2 \Rightarrow$  can reach  $N \approx 15$  on PCs

- \* Present studies use rHMC (HMC) for  $N_f=1$  (2)

- Using  $U^{\text{adj}} \sim U \cdot U^\dagger$ , scaling is  $\sim(N^3) \times N$
- Can reach  $N=53$  on PCs

# Results for $N_f=1$ AEK model

# Last year: reduction works for $N_f=1$

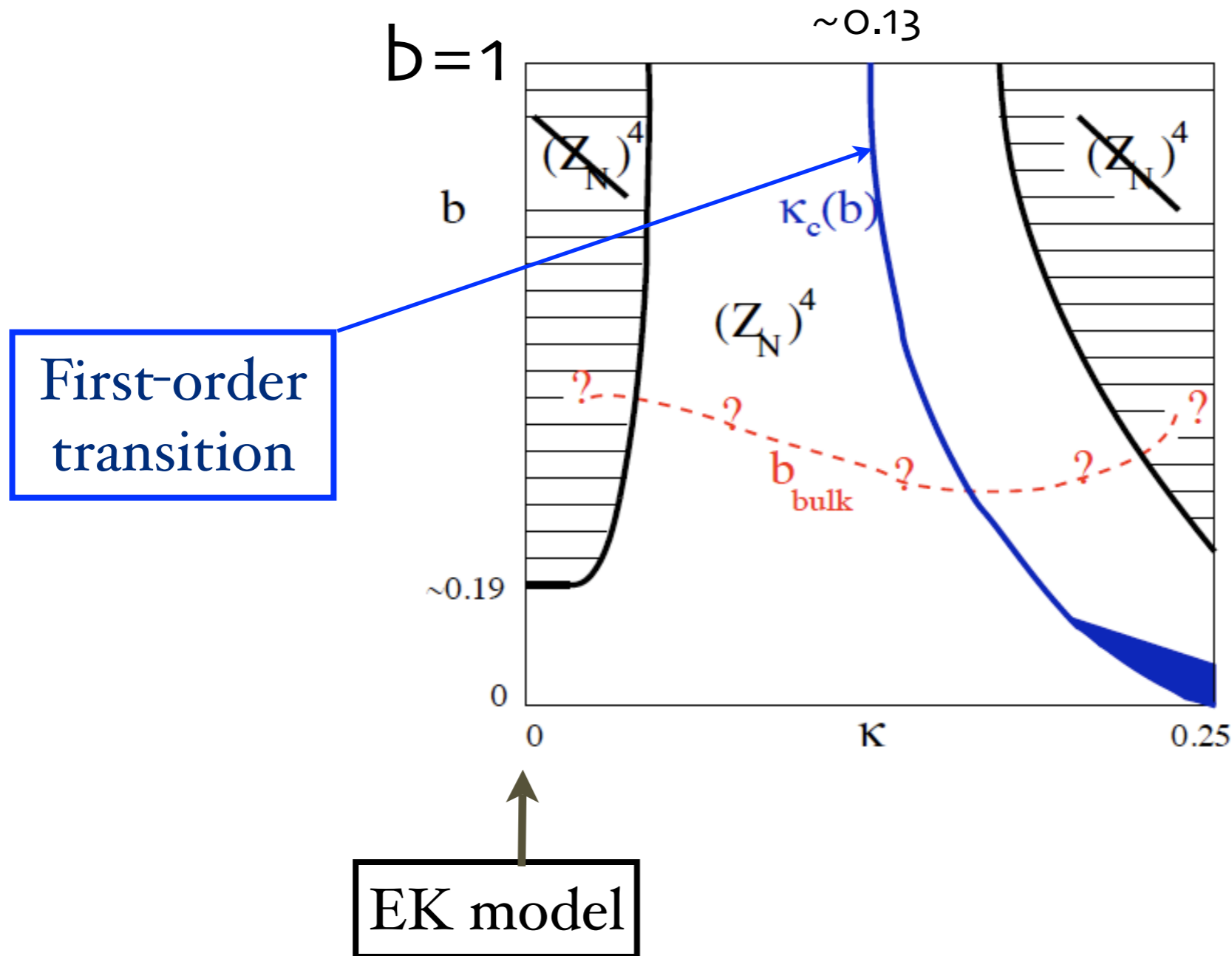

Based on  $N \leq 15$ ; shows weak  $N$  dependence

# Last year: reduction works for $N_f=1$

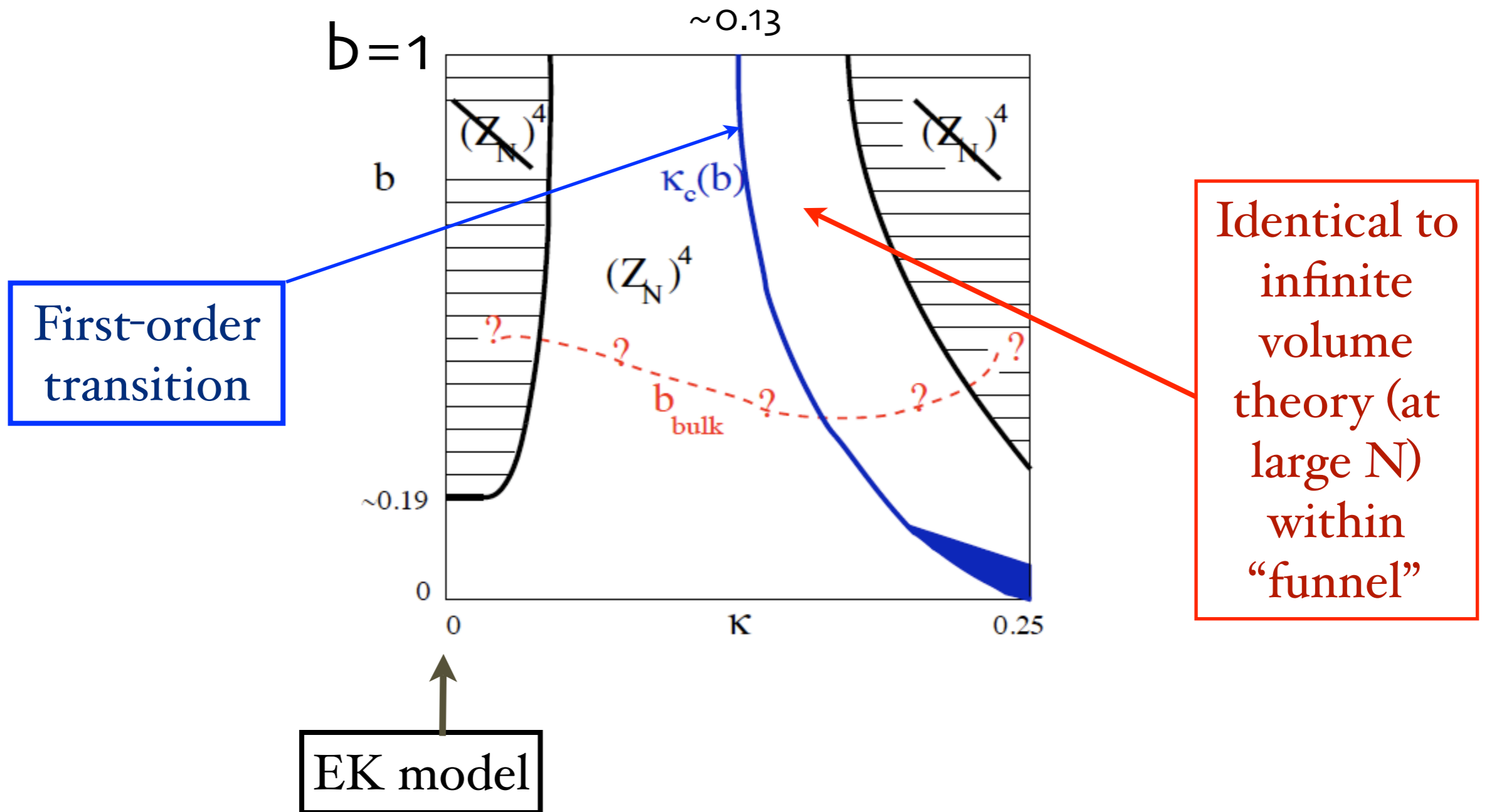

Based on  $N \leq 15$ ; shows weak  $N$  dependence

# Very surprising feature:

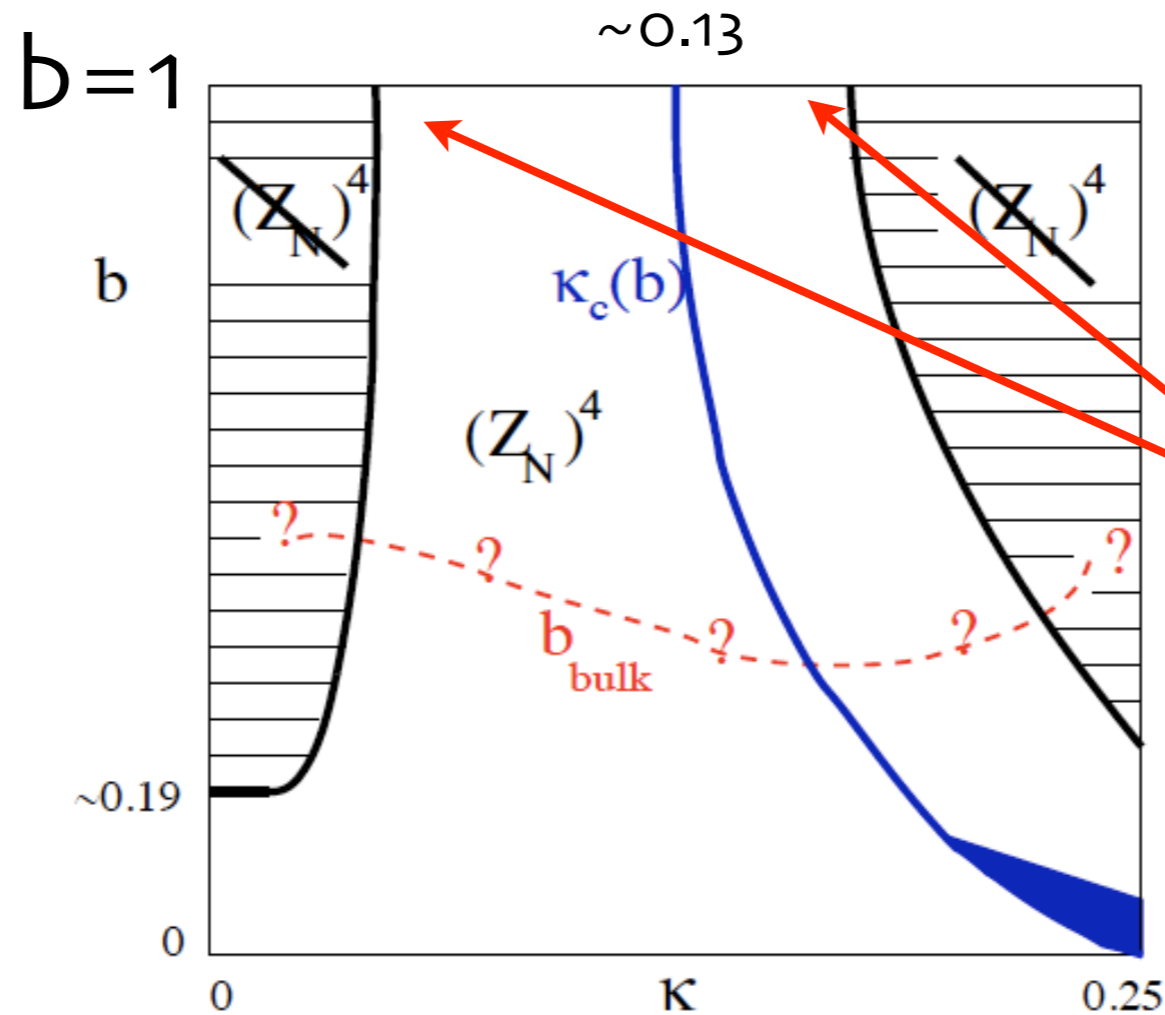

Heavy Quarks  
( $m_{\text{phys}} \sim 1/a$ )  
can “save”  
large- $N$   
reduction!

- \* Inconsistent with naive application of perturbation theory [which requires  $m_{\text{phys}} = O(1/N)$ ]
- \* Violates naive decoupling of heavy quarks

# Very surprising feature:

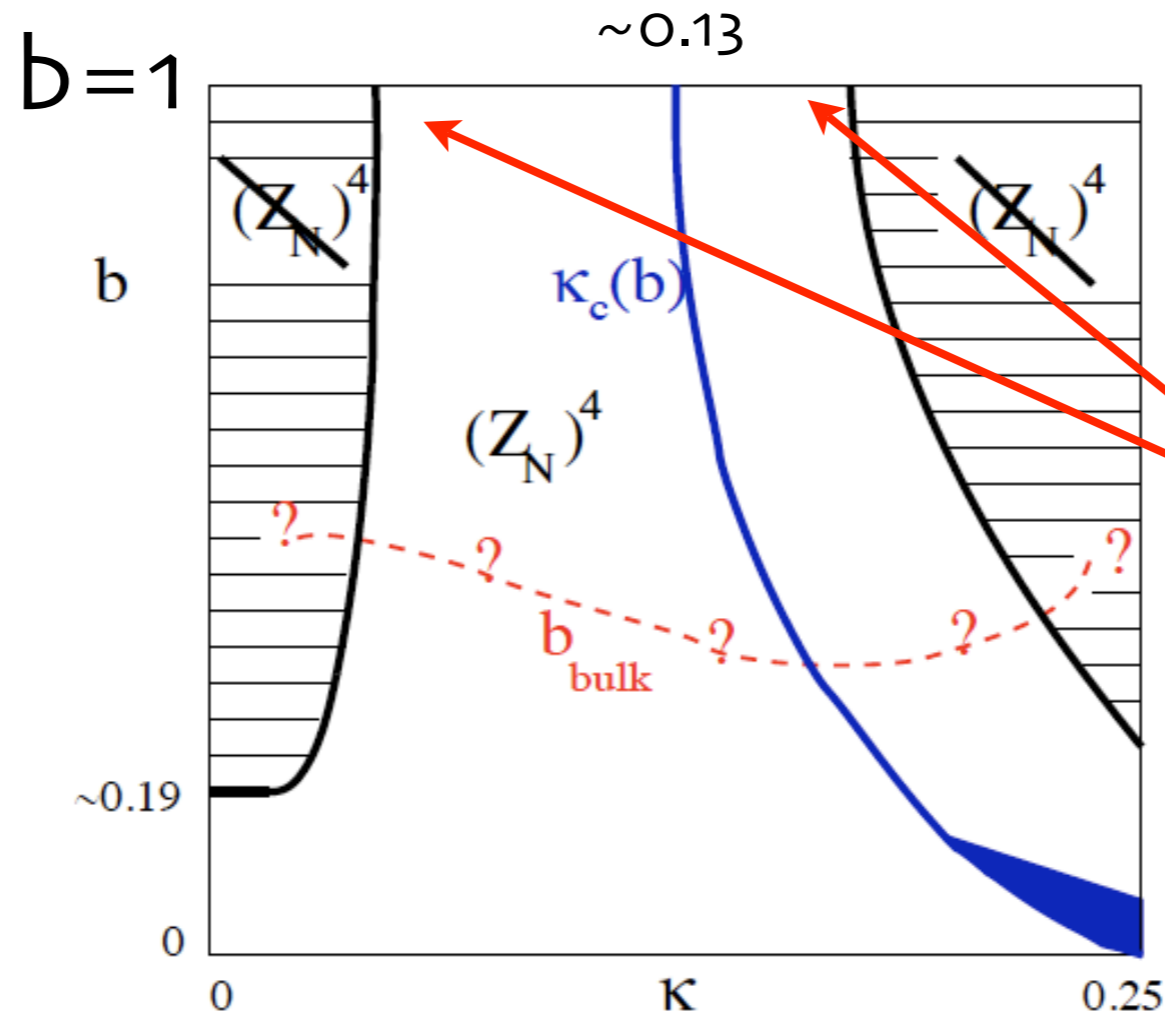

Heavy Quarks  
( $m_{\text{phys}} \sim 1/a$ )  
can “save”  
large-N  
reduction!

\* Checked using rHMC by [Azeyanagi, Hanada, Unsal & Yacoby]

\* Supported by analytic arguments going beyond PT  
[AHUY, Unsal & Yaffe]

➔ Predicts that funnel closes as  $|am_{\text{phys}}| < \frac{1}{b^{1/4}}$

# Last year's plan:

## Conclusions & Future Work

- \* Reduction works for QCD(Adj)!
- \* Next step (1): Calculate observables
  - Pion propagators (test hypothesis about critical line)
  - String tension
  - Spectrum of adjoint fermion (approach to epsilon-regime depends on  $N^2$ )
- \* Next step (2): Algorithmic improvements to allow work at larger  $N$
- \* Next step (3): extend to  $N_f=2$  (nearly conformal th $y$ )

# Last year's plan:

## Conclusions & Future Work

- \* Reduction works for QCD(Adj)!
- \* Next step (1): Calculate observables
  - Pion propagators (test hypothesis about critical line)
  - String tension ✓
  - Spectrum of adjoint fermion (approach to epsilon-regime depends on  $N^2$ ) ✓
- \* Next step (2): Algorithmic improvements to allow work at larger  $N$  ✓
- \* Next step (3): extend to  $N_f=2$  (nearly conformal th) ✓

# Results for $N_f=2$ AEK model

# Phase diagram for $N_f=2$ (using $N$ up to 37)

[B,K & S, in progress]

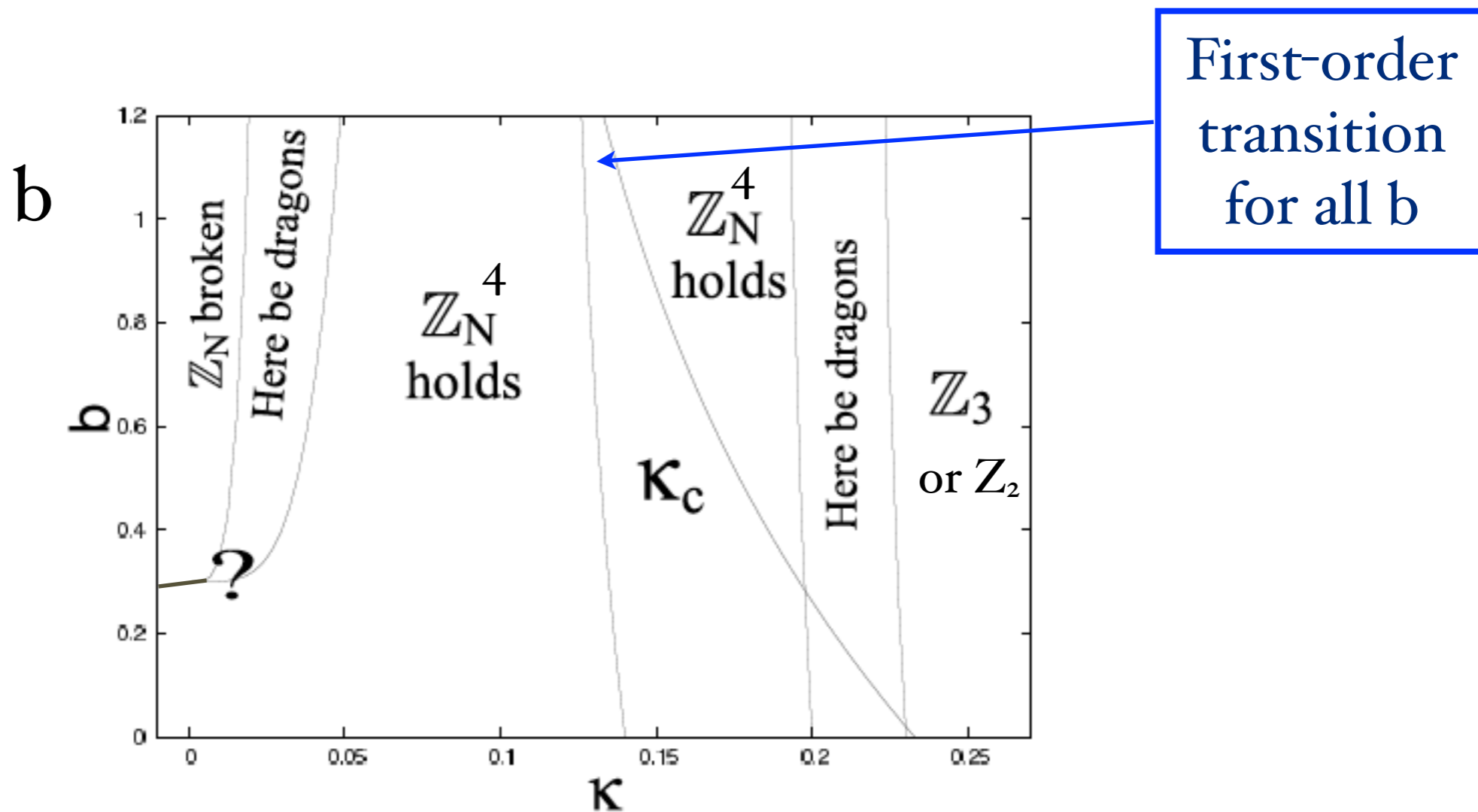

\* As for  $N_f=1$ , vol. indep. holds for wide range of  $m$

# Phase diagram for $N_f=2$ (using $N$ up to 37)

[B,K & S, in progress]

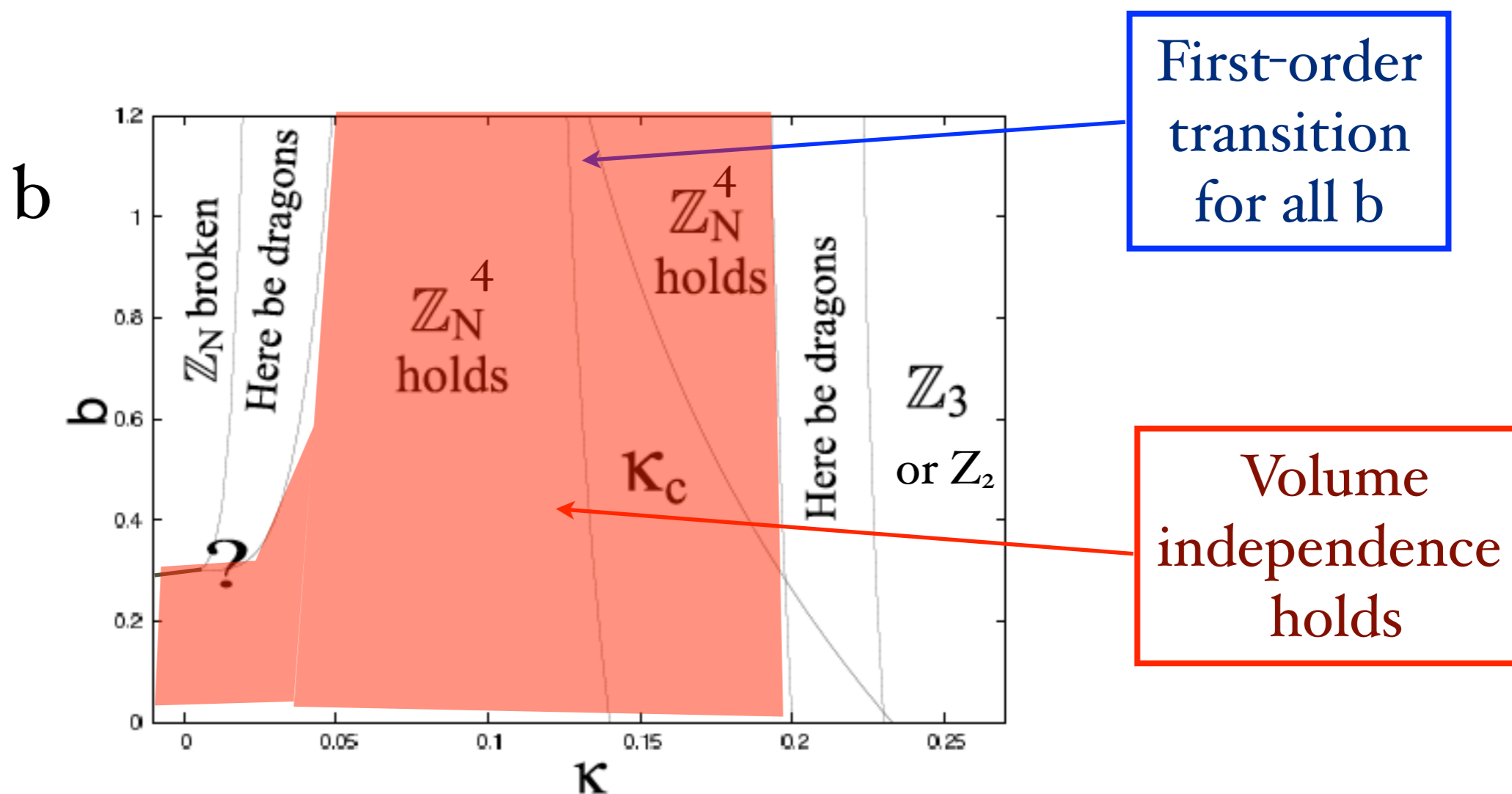

\* As for  $N_f=1$ , vol. indep. holds for wide range of  $m$

# Phase diagram for $N_f=2$ (using $N$ up to 37)

[B,K & S, in progress]

Complicated pattern of clumping of link eigenvalues

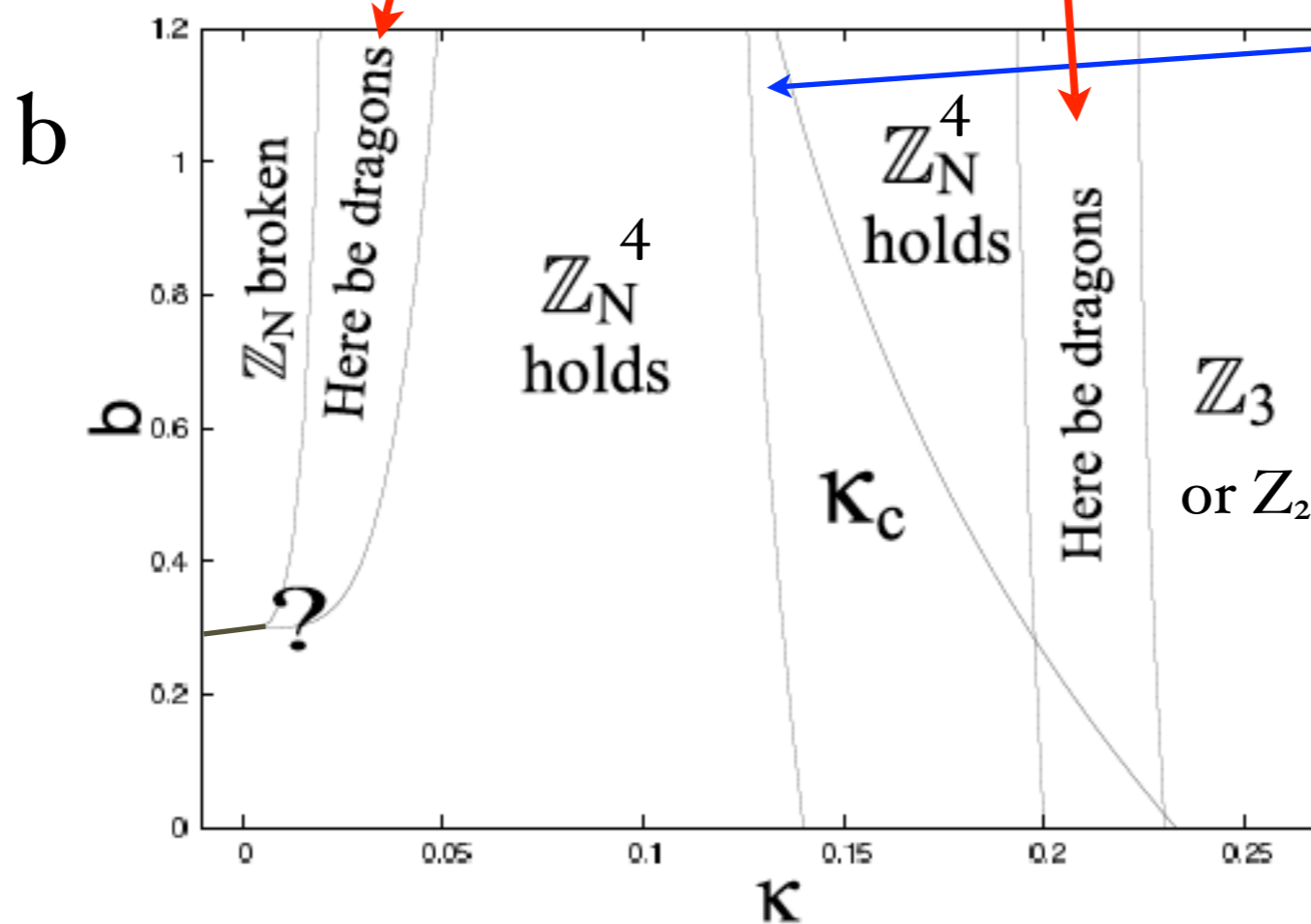

First-order transition for all  $b$

- \* Qualitatively consistent with analytic arguments

# Hysteresis scans at $b=1$ ( $N=10,16,23,30$ )

[B,K & S, in progress]

plaquette

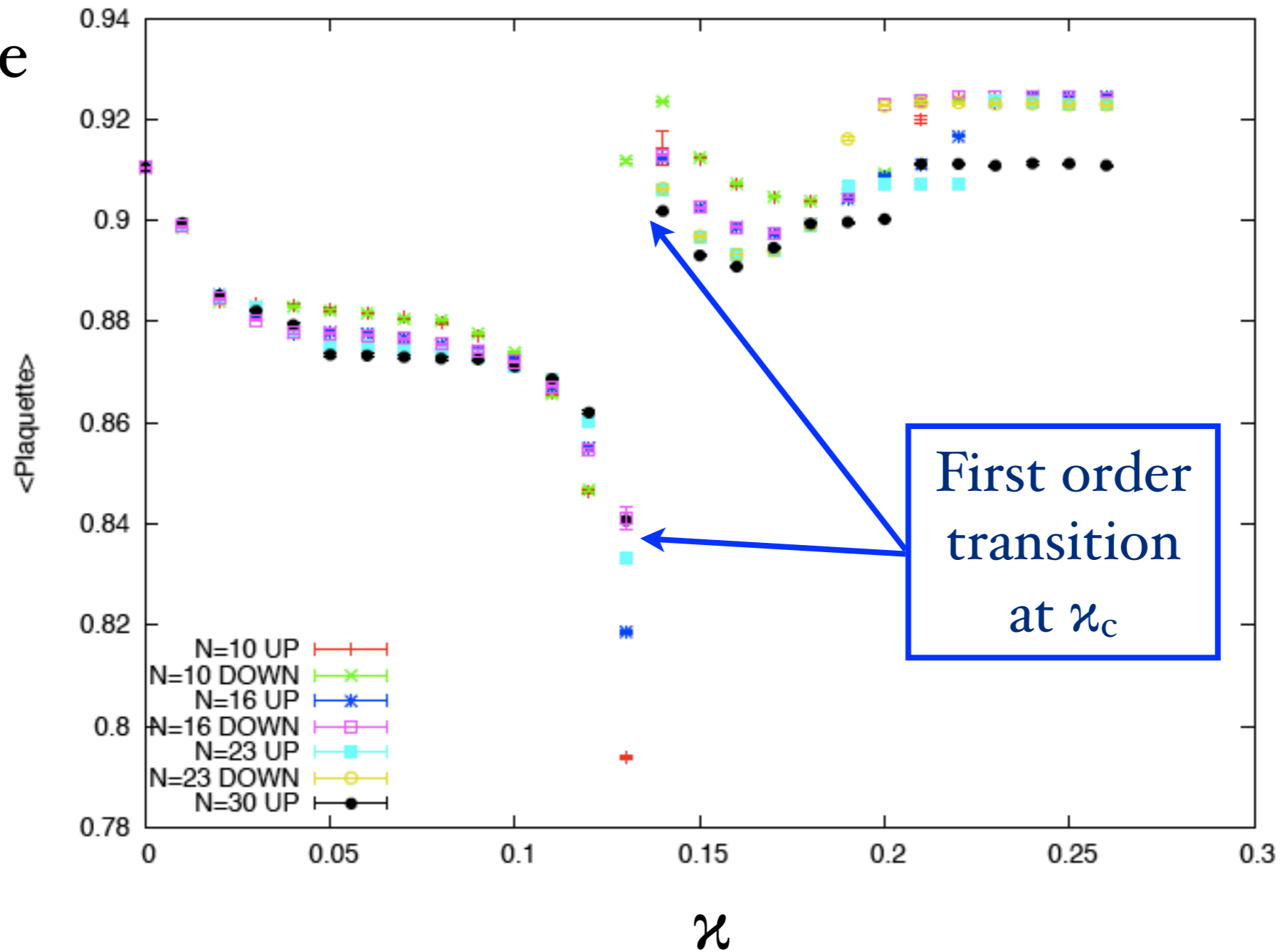

# Hysteresis scans at $b=1$ ( $N=10,16,23,30$ )

[B,K & S, in progress]

plaquette

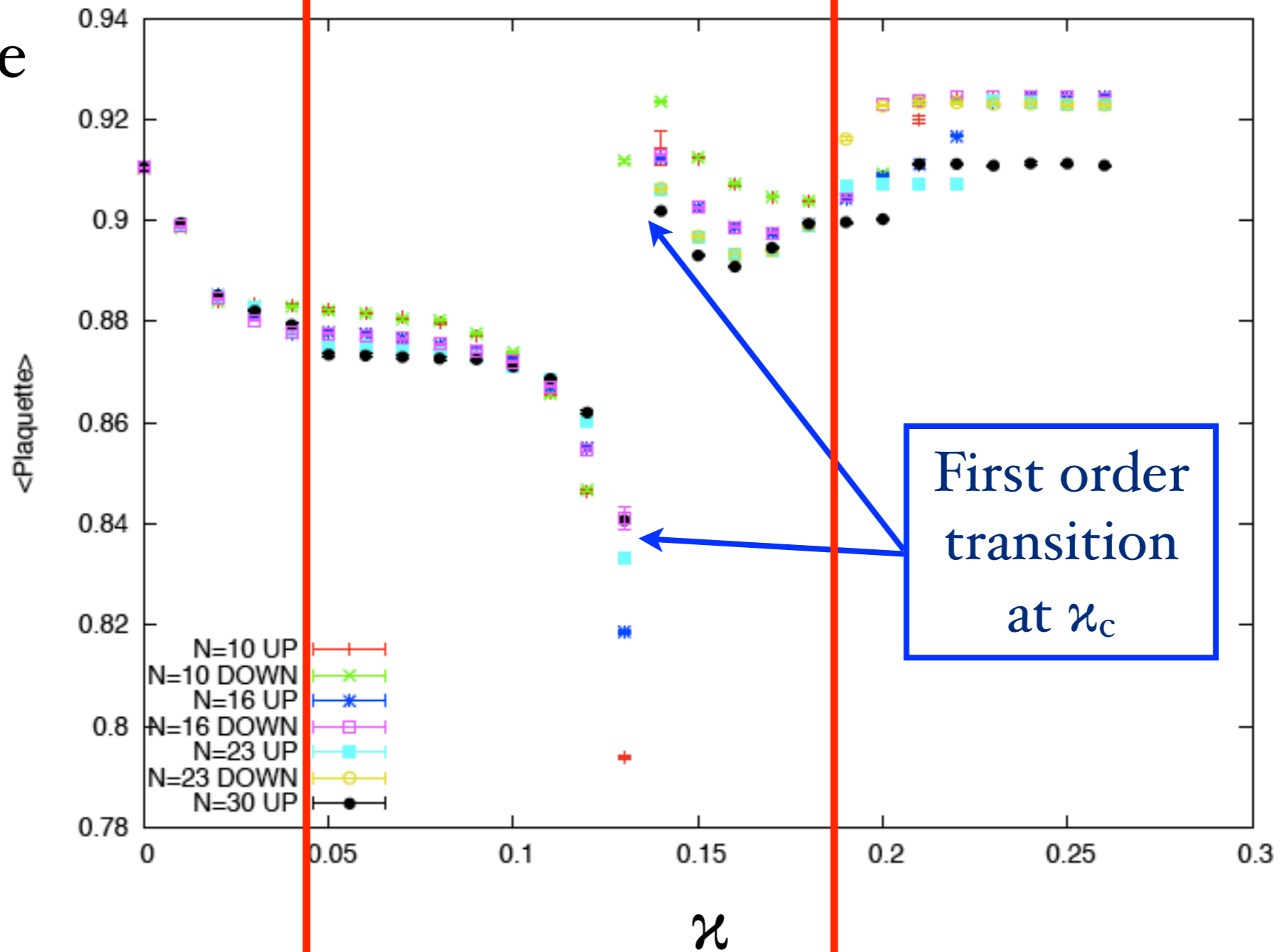

# Hysteresis scans at $b=1$ ( $N=10,16,23,30$ )

[B,K & S, in progress]

$$|\text{tr}(U_\mu U_\nu)|$$

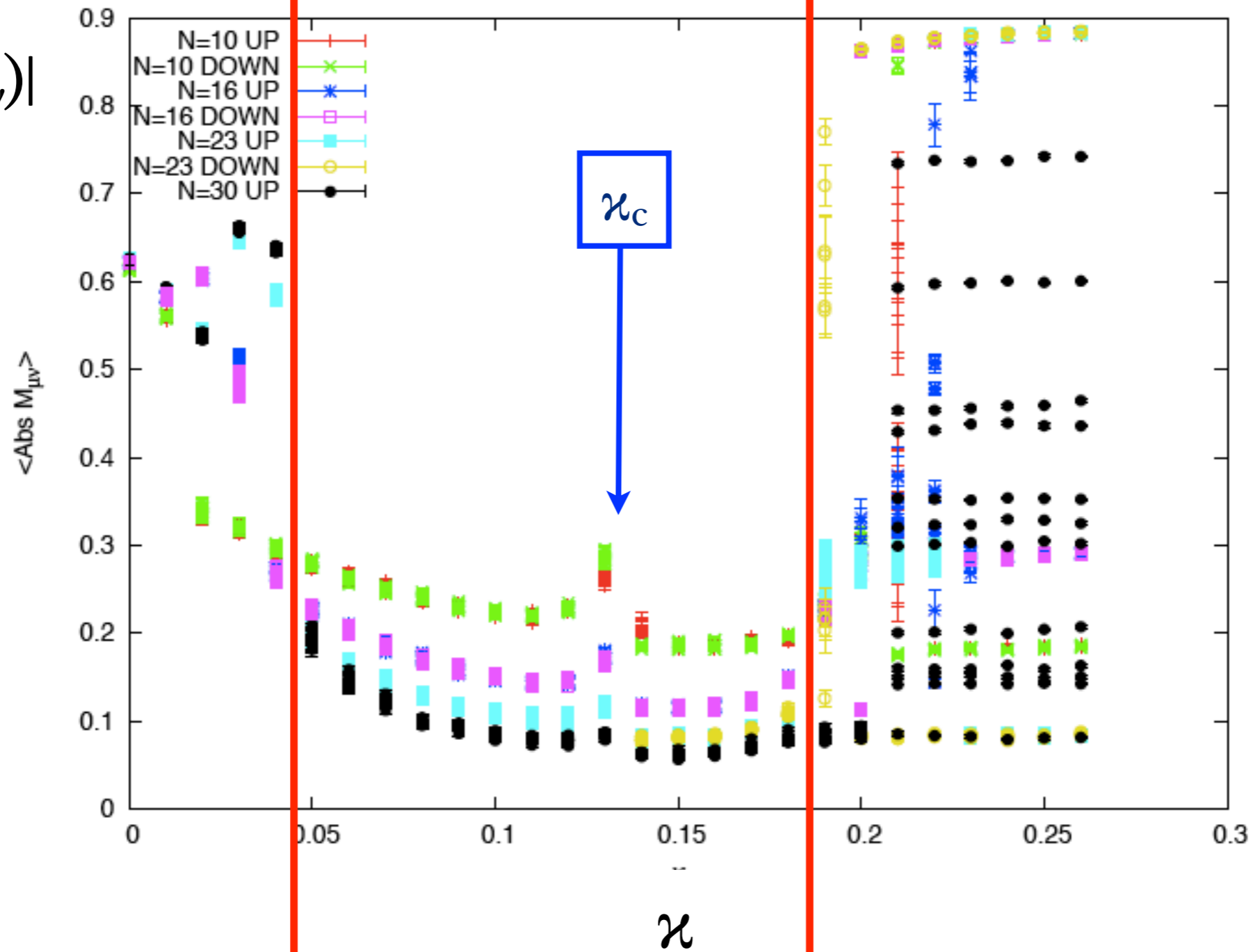

$N_f=2$

# Next test: physical quantities

- \* Wilson loops  $W(N,L)$  in single site theory

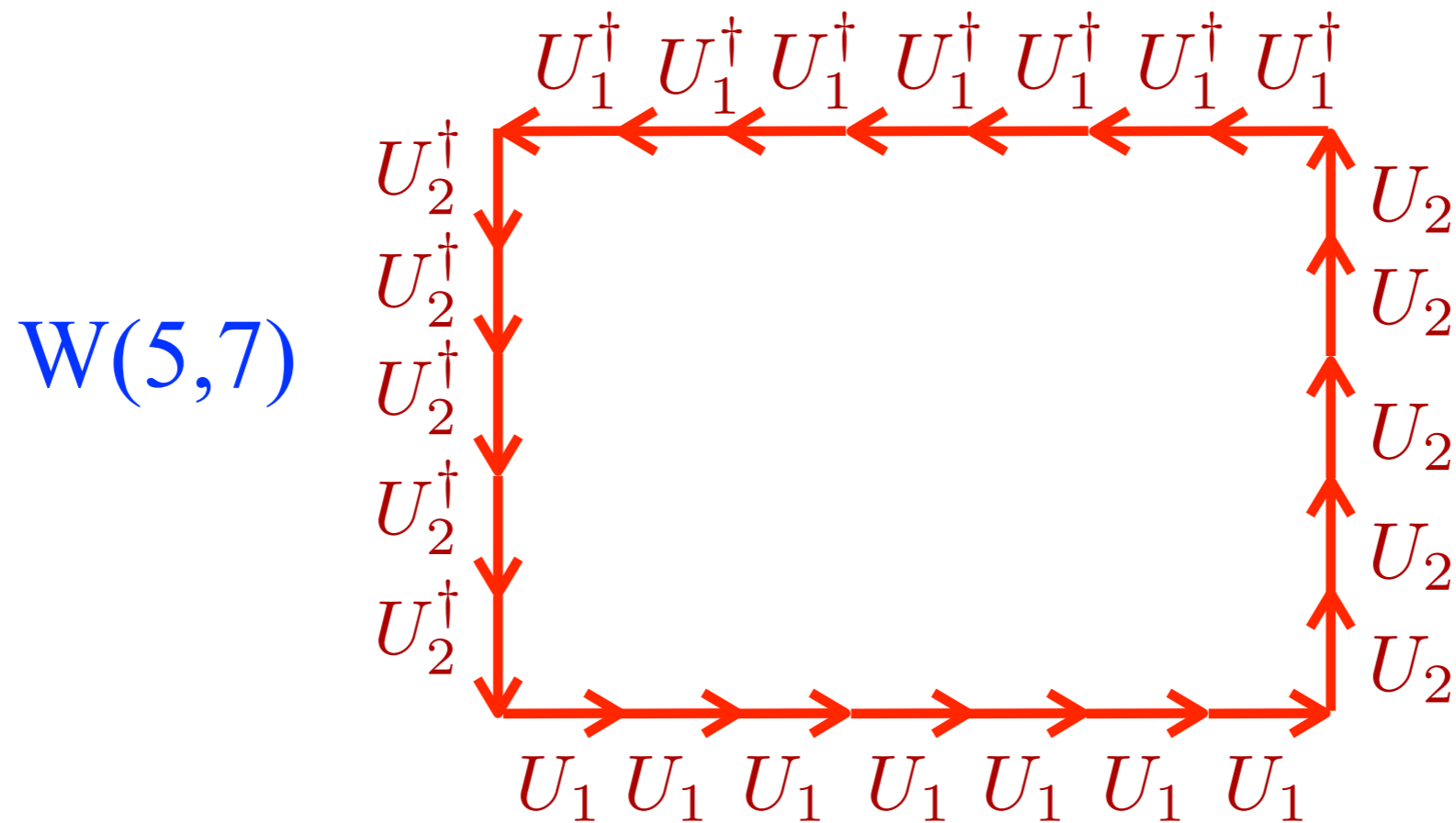

- \* In infinite volume, can extract heavy quark potential

$$\log(W(N, L)) \xrightarrow{L \rightarrow \infty} -V(N)L$$

# Results for 1xL Wilson loops

\*  $N_f=2, b=0.35, K=0.12$

$$\log(W(1, L)) \xrightarrow{L \rightarrow \infty} -V(1)L$$

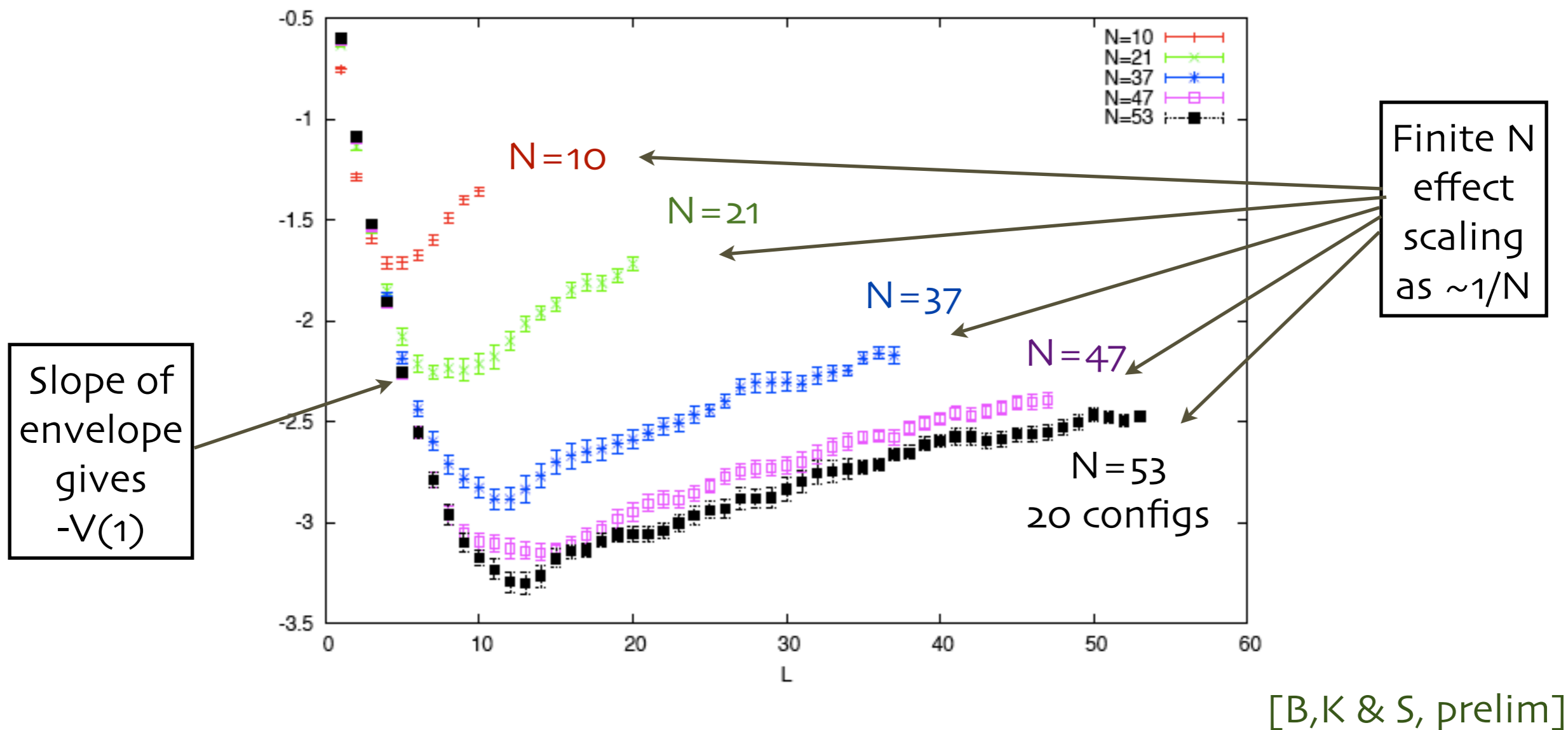

FIG. 6: Log of  $1 \times L$  Wilson loop vs  $L$  for various  $N$ .

[B,K & S, prelim]

# Results for 5xL Wilson loops

- \* Need larger N to determine V(5)
- \* Statistics is not the problem

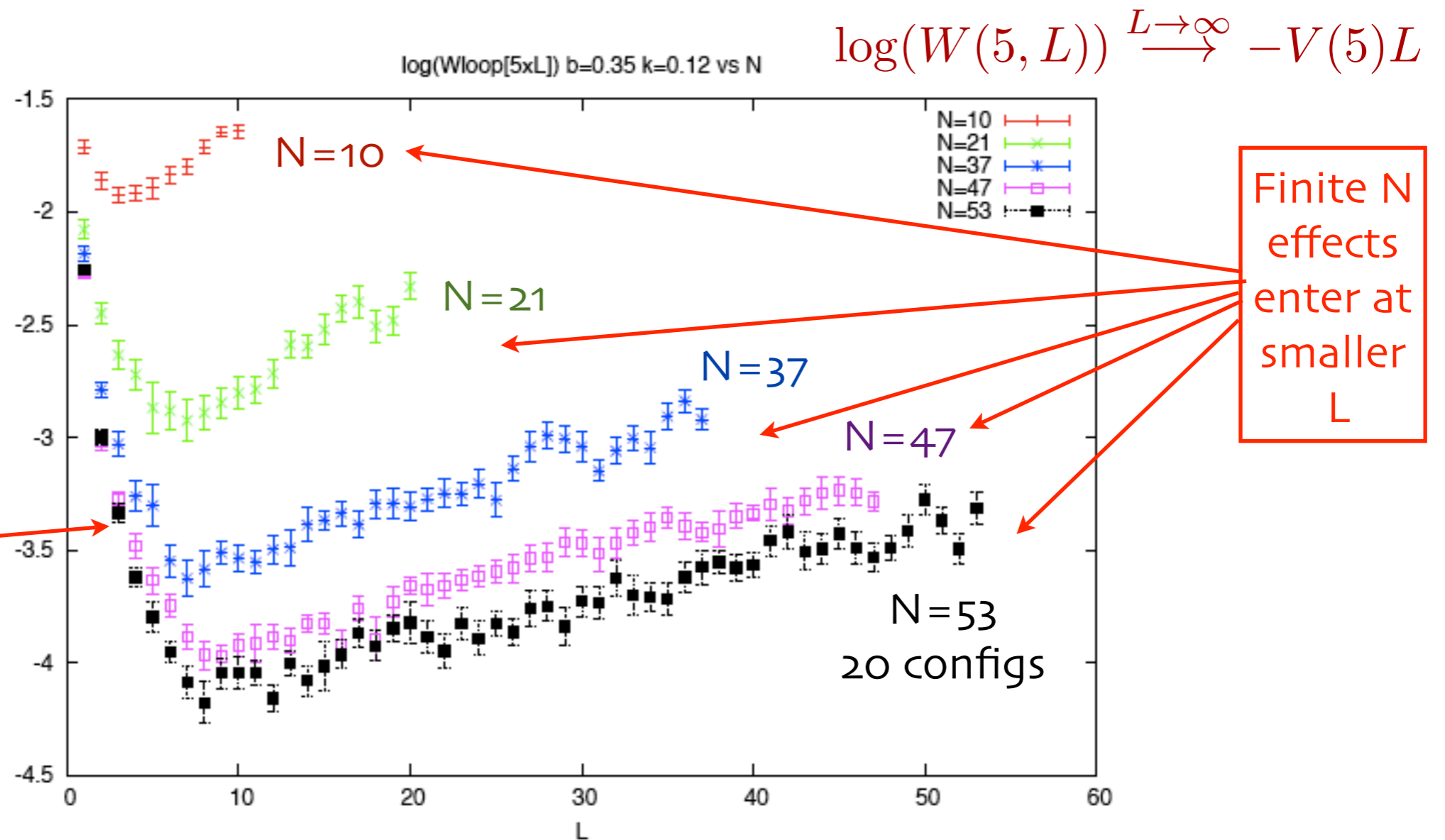

FIG. 8: Log of  $5 \times L$  Wilson loop vs  $L$  for various  $N$ .

[B,K & S, prelim]

# Spectrum of $D_w(\text{adj}, m_0=0)$

- \* Shows 5 fingered structure characteristic of 4 large dimensions

$N_f=2, b=1, \kappa=0.12, N=37$

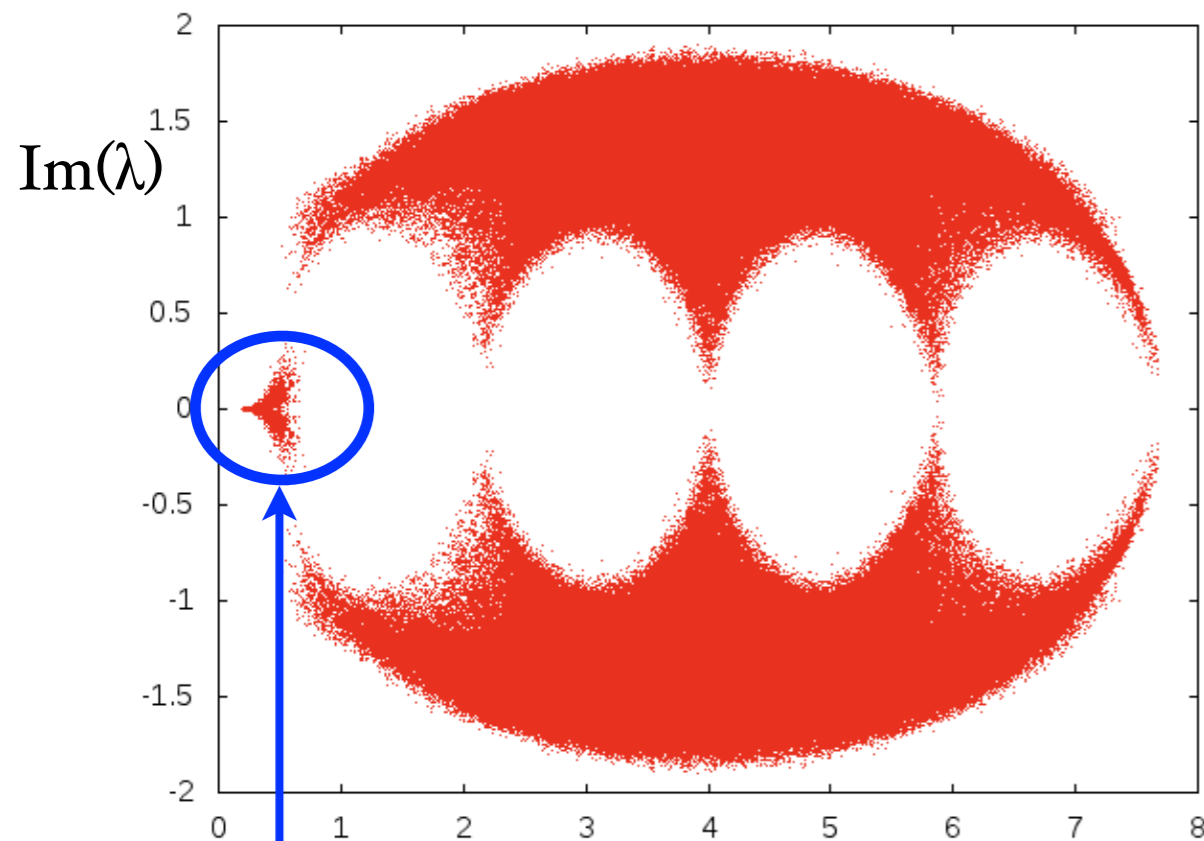

1/N artifact

17<sup>4</sup> lattice, weak coupling

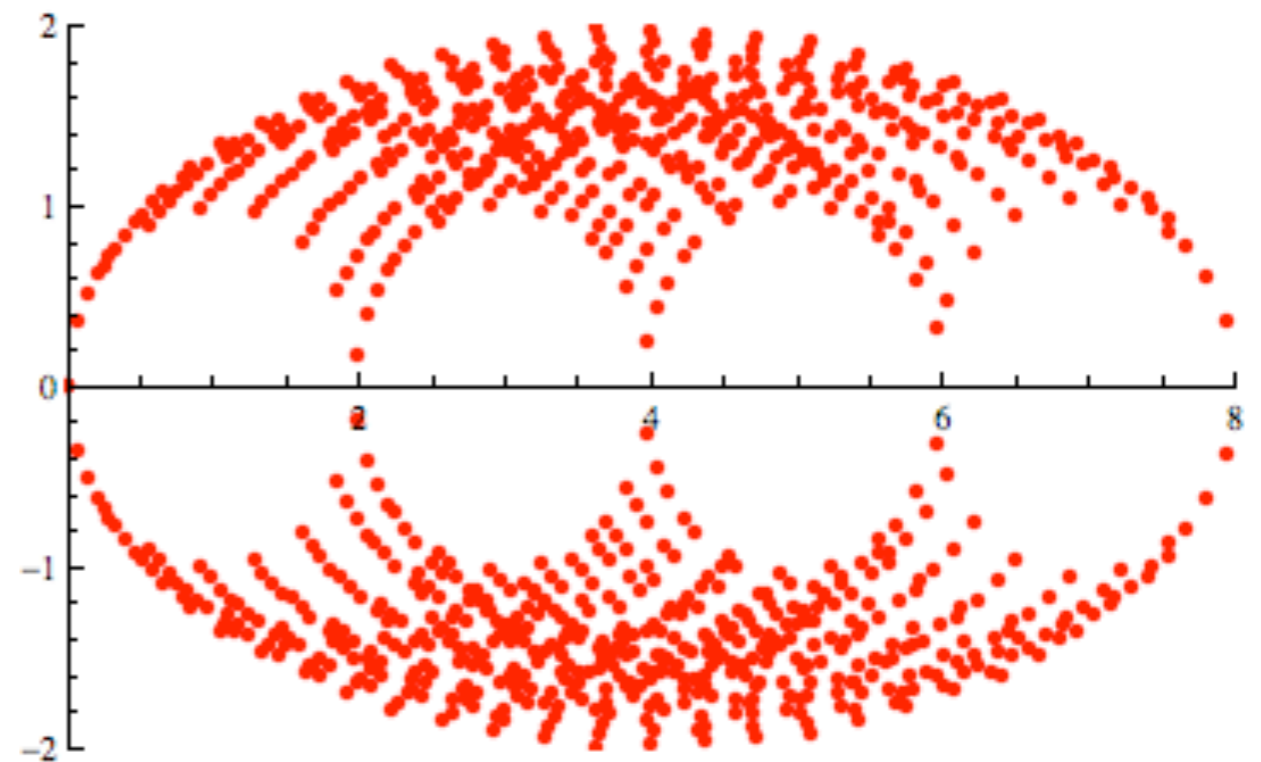

Re( $\lambda$ )

# Conclusions & Future Work

- \* Reduction works for QCD(Adj) with  $N_f=1$  & 2
  - Appears possible to extract physical quantities
- \* Key questions:
  - How does effective size depend on  $N$ :  $L_{\text{eff}} \sim N^{1/4}$ ,  $N^{1/2}$  or  $N$ ?
  - How large an  $N$  is needed to obtain all physical quantities of interest?
- \* Plans for next year:
  - Finish  $N_f=2$  study & write up
  - Extend  $N_f=1$  work to larger  $N$
  - Move to  $N > 50$ , using larger scale resources (GPUs and/or clusters using several sites, e.g.  $2^4$ ,  $3^4$ , etc. Use GPUs?