

Fall 1999 Qualifying Exam: Basic Physics

Problem 1 (50 points)

You are given a thin rod length L with uniform mass density and uniform cross section $\ll L^2$. Let M denote the mass of the rod. This rod is equipped with two movable massless pivots so that it can be used as a physical pendulum with an adjustable period about either of two positions. Let h_1 and h_2 (both taken as positive numbers) denote the displacement of the pivots with respect to the center of mass of the rod. Let g denote the gravitational acceleration due to the Earth.

A. (10 points) Calculate the moment of inertia about either pivot point as a function of h_i .

B. (15 points) Calculate the frequency ω of small oscillations about a pivot point.

C. (10 points) Your result to part B should be multi-valued, i.e. for some frequencies ω there are multiple values for $h < L/2$. Given a pair of distinct pivot positions $h_1 < h_2$ with the same ω , show that $g = (h_1 + h_2)\omega^2$.

D. (15 points) Briefly, qualitatively, discuss whether determination of g using the result of part C is experimentally superior or inferior to the immediate use of the result of part B. (Hint: how sensitive is part B to irregularities of the rod? How sensitive is part C?)

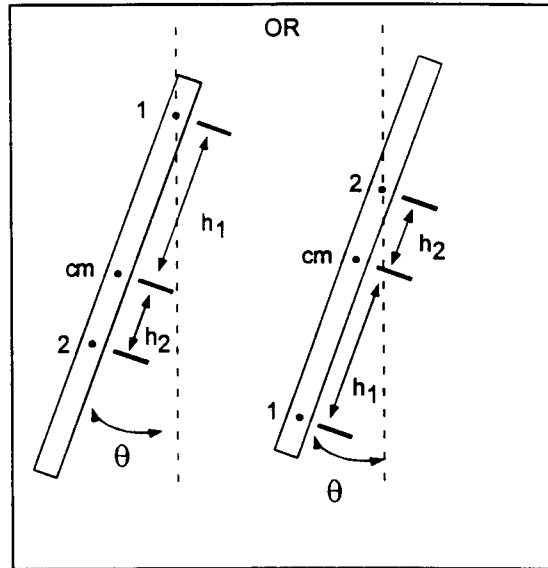

Problem 2 (25 points)

The angular-dependence of monochromatic optical-wavelength light scattering can be used to determine the size of small spherical particles suspended in a water solution. However, this technique becomes unreliable if a significant fraction of the detected scattered radiation has been multiply-scattered (rather than just singly-scattered) by the small spherical particles in the sample. Briefly propose an experimental test to quantify the contribution to the scattered intensity from multiple scattering. Ignore any absorption in the sample. Your answer should include a brief description and/or a sketch of your apparatus. Explain your answer. Available equipment includes (but is not limited to): polarizers, detectors, lenses, pinholes, mirrors, glassware, more lasers, etc.

Problem 3 (25 points)

Short Answer Questions.

A. (10 points) Major volcanic explosions can push a large amount of dust particles high into the stratosphere. After major eruptions, the moon (as observed from the Earth) often has a red tint. Explain this observation. In particular, also explain what this observation tells you about the size distribution of the dust particles.

B. (15 points) Two physics graduate students are taking a summer vacation in the New Mexico desert. During a daytime hike on level ground, the students reliably observe that

the desert floor appears to be reflecting (giving the false appearance of a rippling mirror or pond of water) at a distance of a few hundred meters from where they are standing. Give a qualitative explanation for their observations.